

---

**Travail de fin d'études et stage[BR]- Travail de fin d'études : Conception du système de mesure de la bande analytique de la ligne de tri "PickIt"[BR]- Stage d'insertion professionnelle : Laboratoire Gemme (ArGenCo)**

**Auteur :** Senger, Antoine

**Promoteur(s) :** Bruls, Olivier

**Faculté :** Faculté des Sciences appliquées

**Diplôme :** Master en ingénieur civil mécanicien, à finalité spécialisée en technologies durables en automobile

**Année académique :** 2023-2024

**URI/URL :** <http://hdl.handle.net/2268.2/19593>

---

*Avertissement à l'attention des usagers :*

*Tous les documents placés en accès ouvert sur le site le site MatheO sont protégés par le droit d'auteur. Conformément aux principes énoncés par la "Budapest Open Access Initiative"(BOAI, 2002), l'utilisateur du site peut lire, télécharger, copier, transmettre, imprimer, chercher ou faire un lien vers le texte intégral de ces documents, les disséquer pour les indexer, s'en servir de données pour un logiciel, ou s'en servir à toute autre fin légale (ou prévue par la réglementation relative au droit d'auteur). Toute utilisation du document à des fins commerciales est strictement interdite.*

*Par ailleurs, l'utilisateur s'engage à respecter les droits moraux de l'auteur, principalement le droit à l'intégrité de l'oeuvre et le droit de paternité et ce dans toute utilisation que l'utilisateur entreprend. Ainsi, à titre d'exemple, lorsqu'il reproduira un document par extrait ou dans son intégralité, l'utilisateur citera de manière complète les sources telles que mentionnées ci-dessus. Toute utilisation non explicitement autorisée ci-avant (telle que par exemple, la modification du document ou son résumé) nécessite l'autorisation préalable et expresse des auteurs ou de leurs ayants droit.*

---



# Safety Manual

PRODUCT NAME

## *Step Motor Controller with STO Sub-Function*

MODEL / Series / Product Number

### JXC\*F

- ORIGINAL INSTRUCTIONS -

## SMC Corporation



## IMPORTANT

This product is intended to be used in applications requiring the safe stopping and the prevention of unexpected start-up of a 24VDC stepper motor. It is the user's responsibility to determine if this product is suitable for the intended application and to specify the arrangement of the safety system to achieve the required safety function.

This manual is only valid for the JXC□F with the following product version(s) in Table 0-1 below.

For the functions and specifications not related to safety functions, please refer to the corresponding standard manuals listed in Table 0-1 below.

Table 0-1: Applicable products and documents

Start of the Product number*	protocol	Safety HW version	Manual document No. for standard functions excluding safety
JXCEF	EtherCAT	1.1	JXC#-OMU0008 JXC#-OMY0008
JXC9F	EtherNet/IP	1.1	SFOD-OMT0006 JXC#OMY0006
JXCPF	PROFINET	1.1	JXC#-OMT0006
JXCLF	IO-Link	1.1	JXC#-OMV0005

\*The rest of the full product number contains a number that indicates the actuator.

**The original language of the Safety Manual is English.**

**Manuals that have been translated into other languages should be used for reference only.**

# Contents

IMPORTANT	1
Contents	2
1. Safety Instructions for Functional Safety	11
1.1. General safety notes	11
1.2. Electrical safety	13
1.3. Safety of the machine or system	14
1.4. Directive and standards	14
1.5. Abbreviations used	14
2. Product Outline	15
2.1. Features	15
2.2. How to Order	17
2.3. Product Configuration	17
3. Specifications	18
3.1. Basic Specifications	18
3.2. Safety Specifications	19
3.3. STO Connector Electrical Specifications	20
3.4. Name and function of Parts	21
3.5. External Dimensions	25
3.6. Mounting	27
4. Initial Setting Method	28
5. External Connection	30
6. Power Supply Plug	30
7. LED Display	30
8. Operation Methods	30
9. Memory Map	30
10. Setting Data Entry	30
10.1. Step Data	30
10.2. Basic Parameters	30
10.3. Return to Origin Parameter	30
11. Operations	30
11.1. Return to Origin Position	30
11.2. Positioning Operation	30
11.3. Pushing Operation	30
11.4. Control input signal response time	30
11.5. Methods of interrupting operation	30
11.6. SS1-t Operation	31
12. Start-up Procedure for JXC□F with STO Sub-function	38
13. Operation Instructions	40
14. Option	40

15. Alarm Detection for Motor Control	40
16. Specific Precautions for STO Sub-function	40
16.1. Misuse of SS1-t and STO Sub-functions	41
16.2. Maintenance and Repairs	41
17. Troubleshooting	42
17.1. Failure Modes	43
18. Appendix A: Checklists	44



# JXC\*F/Controller Safety Instructions

These safety instructions are intended to prevent hazardous situations and/or equipment damage. These instructions indicate the level of potential hazard with the labels of "Caution," "Warning" or "Danger."

They are all important notes for safety and must be followed in addition to International Standards (ISO/IEC)\*1), and other safety regulations.

\*1) ISO 4414: Pneumatic fluid power -- General rules relating to systems.

ISO 4413: Hydraulic fluid power -- General rules relating to systems.

IEC 60204-1: Safety of machinery -- Electrical equipment of machines .(Part 1: General requirements)

ISO 10218: Manipulating industrial robots -Safety. etc.



## Caution

**Caution** indicates a hazard with a low level of risk which, if not avoided, could result in minor or moderate injury.



## Warning

**Warning** indicates a hazard with a medium level of risk which, if not avoided, could result in death or serious injury.



## Danger

**Danger** indicates a hazard with a high level of risk which, if not avoided, will result in death or serious injury.

## Warning

### 1. The compatibility of the product is the responsibility of the person who designs the equipment or decides its specifications.

Since the product specified here is used under various operating conditions, its compatibility with specific equipment must be decided by the person who designs the equipment or decides its specifications based on necessary analysis and test results.

The expected performance and safety assurance of the equipment will be the responsibility of the person who has determined its compatibility with the product.

This person should continuously review all specifications of the product referring to its latest catalog information, with a view to giving due consideration to any possibility of equipment failure when configuring the equipment.

### 2. Only personnel with appropriate training should operate machinery and equipment.

The product specified here may become unsafe if handled incorrectly.

The assembly, operation and maintenance of machines or equipment including our products must be performed by an operator who is appropriately trained and experienced.

### 3. Do not service or attempt to remove product and machinery/equipment until safety is confirmed.

1. The inspection and maintenance of machinery/equipment should only be performed after measures to prevent falling or runaway of the driven objects have been confirmed.

2. When the product is to be removed, confirm that the safety measures as mentioned above are implemented

and the power from any appropriate source is cut, and read and understand the specific product precautions

of all relevant products carefully.

3. Before machinery/equipment is restarted, take measures to prevent unexpected operation and malfunction.

### 4. Contact SMC beforehand and take special consideration of safety measures if the product is to be used in any of the following conditions.

1. Conditions and environments outside of the given specifications, or use outdoors or in a place exposed to direct sunlight.

2. Installation on equipment in conjunction with atomic energy, railways, air navigation, space, shipping, vehicles, military, medical treatment, combustion and recreation, or equipment in contact with food and beverages, emergency stop circuits, clutch and brake circuits in press applications, safety equipment or other applications unsuitable for the standard specifications described in the product catalog.

3. An application which could have negative effects on people, property, or animals requiring special safety analysis.

4. Use in an interlock circuit, which requires the provision of double interlock for possible failure by using a mechanical protective function, and periodical checks to confirm proper operation.



# JXC\*F/Controller

## Safety Instructions

### **Caution**

**The product is provided for use in manufacturing industries.**

The product herein described is basically provided for peaceful use in manufacturing industries.

If considering using the product in other industries, consult SMC beforehand and exchange specifications or a contract if necessary.

If anything is unclear, contact your nearest sales branch.

## Limited warranty and Disclaimer/Compliance Requirements

The product used is subject to the following "Limited warranty and Disclaimer" and "Compliance Requirements".

Read and accept them before using the product.

### Limited warranty and Disclaimer

- 1. The warranty period of the product is 1 year in service or 1.5 years after the product is delivered, whichever is first. \*2)**  
Also, the product may have specified durability, running distance or replacement parts. Please consult your nearest sales branch.
- 2. For any failure or damage reported within the warranty period which is clearly our responsibility, a replacement product or necessary parts will be provided.**  
This limited warranty applies only to our product independently, and not to any other damage incurred due to the failure of the product.
- 3. Prior to using SMC products, please read and understand the warranty terms and disclaimers noted in the specified catalog for the particular products.**  
\*2) Vacuum pads are excluded from this 1 year warranty.  
A vacuum pad is a consumable part, so it is warranted for a year after it is delivered.  
Also, even within the warranty period, the wear of a product due to the use of the vacuum pad or failure due to the deterioration of rubber material are not covered by the limited warranty.

### Compliance Requirements

- 1. The use of SMC products with production equipment for the manufacture of weapons of mass destruction (WMD) or any other weapon is strictly prohibited.**
- 2. The exports of SMC products or technology from one country to another are governed by the relevant security laws and regulation of the countries involved in the transaction. Prior to the shipment of a SMC product to another country, assure that all local rules governing that export are known and followed.**

### **Caution**

**SMC products are not intended for use as instruments for legal metrology.**

Measurement instruments that SMC manufactures or sells have not been qualified by type approval tests relevant to the metrology (measurement) laws of each country.

Therefore, SMC products cannot be used for business or certification ordained by the metrology (measurement) laws of each country.

## Operator

- ◆ This operation manual has been written for those who have knowledge of machinery and apparatus that use motor drives and have full knowledge of assembly, operation and maintenance of such equipment.
- ◆ Please read this operation manual carefully and understand it before assembling, operating or providing maintenance to the product.

## ■ Precautions

### **Danger**

- After maintenance is complete, perform appropriate functional inspections.  
Stop operation if the equipment does not function properly.  
Safety cannot be assured in the case of unexpected malfunction.

### **Warning**

- Do not operate the product outside of the specifications.  
Do not use for flammable or harmful fluids.  
Fire, malfunction, or damage to the product can result.  
Verify the specifications before use.
- Do not operate in an atmosphere containing flammable or explosive gases.  
Fire or an explosion can result.  
This product is not designed to be explosion proof.
- If using the product in an interlocking circuit:
  - Provide a double interlocking system, for example a mechanical system.
  - Check the product regularly for proper operation.  
Otherwise malfunction can result, causing an accident.
- The following instructions must be followed during maintenance:
  - Turn off the power supply.  
Otherwise an injury can result.

### **Caution**

- Provide grounding to assure the noise resistance of the product using fieldbus.  
Individual grounding should be provided close to the product with a short cable.



## ■NOTE

- Follow the instructions given below when designing, selecting and handling the product.
  - The instructions on design and selection (installation, wiring, environment, adjustment, operation, maintenance, etc.) described below must also be followed.

### \*Product specifications

- Use the specified voltage.  
Otherwise failure or malfunction can result.
- Reserve a space for maintenance.  
Allow sufficient space for maintenance when designing the system.
- Do not remove any nameplates or labels.  
This can lead to incorrect maintenance, or misreading of the operation manual, which could cause damage or malfunction to the product.  
It may also result in non-conformity to safety standards.

### ●Product handling

#### \*Installation

- Do not drop, hit or apply excessive shock to the product.  
Otherwise damage to the product can result, causing malfunction.
- Tighten to the specified tightening torque.  
If the tightening torque is exceeded the mounting screws may be broken.
- Never mount a product in a location that will be used as a foothold.  
The product may be damaged if excessive force is applied by stepping or climbing onto it.

#### \*Wiring

- Avoid repeatedly bending or stretching the cables, or placing heavy load on them.  
Repetitive bending stress or tensile stress can cause breakage of the cable.
- Wire correctly.  
Incorrect wiring can break the controller.
- Do not perform wiring while the power is on.  
Otherwise damage to the product can result, causing malfunction.
- Do not route wires and cables together with power or high voltage cables.  
Otherwise the product can malfunction due to interference of noise and surge voltage from power and high voltage cables to the signal line.  
Route the wires (piping) of the product separately from power or high voltage cables.
- Confirm proper insulation of wiring.  
Poor insulation (interference from another circuit, poor insulation between terminals, etc.) can lead to excess voltage or current being applied to the controller, causing damage.
- Take appropriate measures against noise, such as using a noise filter, when the product is incorporated into equipment.  
Otherwise noise can cause malfunction.

#### \*Environment

- Do not use in a place where the product could be splashed by oil or chemicals.  
If the product is to be used in an environment containing oils or chemicals such as coolant or cleaning solvent, even for a short time, it may be adversely affected (damage, malfunction etc.).
- Do not use the product in an environment where corrosive gases or fluids could be splashed.  
Otherwise damage to the product and malfunction can result.
- Do not use in an area where surges are generated.  
If there is equipment which generates a large amount of surge (solenoid type lifter, high frequency induction furnace, motor, etc.) close to the fieldbus system, this may cause deterioration or breakage of the internal circuit of the fieldbus system. Avoid sources of surge generation and crossed lines.
- The product is CE marked, but not immune to lightning strikes. Take measures against lightning strikes in the system.
- Prevent foreign matter such as remnant of wires from entering the fieldbus system to avoid failure and malfunction.
- Mount the product in a place that is not exposed to excessive vibration or impact.  
Otherwise failure or malfunction can result.
- Do not use the product in an environment that is exposed to temperature cycle.  
Heat cycles other than ordinary changes in temperature can adversely affect the inside of the product.
- Do not expose the product to direct sunlight.  
If using in a location directly exposed to sunlight, shade the product from the sunlight.  
Otherwise failure or malfunction can result.
- Keep within the specified ambient temperature range.  
Otherwise malfunction can result.
- Do not operate close to a heat source, or in a location exposed to radiant heat.  
Otherwise malfunction can result.

#### \*Adjustment and Operation

- Set the switches by using a sharp-pointed screwdriver etc.  
Caution: Ensure the tool does not damage the switches during this process.
- Perform settings suitable for the operating conditions.  
Caution: Incorrect settings can cause operation failure and unexpected actuator behaviour
- Please refer to the PLC manufacturer's manual etc. for details of programming and addresses.  
For the PLC protocol and programming refer to the relevant manufacturer's documentation.

\*Maintenance

- Perform regular maintenance and inspections.

There is a risk of unexpected malfunction.

- After maintenance is complete, perform appropriate functional inspections.

Stop operation if the equipment does not function properly.

Otherwise safety is not assured due to an unexpected malfunction or incorrect operation.

- Do not use solvents such as benzene, thinner etc. to clean the controller.

They could damage the surface of the body and erase the markings on the body.

Use a soft cloth to remove stains.

For heavy stains, use a cloth soaked with diluted neutral detergent and fully squeezed, then wipe up the stains again with a dry cloth.

# Fieldbus System/ Industrial IoT Cybersecurity

In recent years, factories have introduced industrial IoT, building up complex networks of production machines. These systems may be subject to a new threat, cyberattack. To protect the industrial IoT from cyberattacks, it is important to take multiple measures (multi-layer protection) for IoT devices, networks and clouds.

For this purpose, SMC recommends that the following measures are always taken into consideration. For further details of the following measures, please see security information published by your countries security agencies.

## **1. Do not connect the devices via a public network.**

- If you unavoidably need to access the device or cloud via a public network, ensure to use a secure, private network such as VPN.
- Do not connect an office IT network and factory IoT network.

## **2. Build a firewall to prevent a threat from entering the device and system.**

- Set up a router or firewall at network boundaries to allow minimum required communications.
- Disconnect from the network or turn off the device, if no continuous connection is required.

## **3. Physically block access to unused communication ports or disable them.**

- Inspect regularly each port if any unnecessary device is connected to the network system.
- Operate necessary services (SSH, FTP, SFTP, etc.) only.
- Set a transmission range of the device using a wireless LAN or other radio system to the minimum required and use only devices approved according to the radio act in the country concerned.
- Install a device generating radio waves in such place as there is no interference from indoor or outdoor.

## **4. Set up a secure communication method such as data encryption.**

- Encrypt data in every environment, including IoT networks, secure gate-way connections, for secure communications.

## **5. Grant access permissions by user accounts and limit the number of users.**

- Regularly review accounts and delete all unused accounts or permissions.
- Establish an account lockout system to block an access to the account for a certain period if log-in fails more than the given threshold.

## **6. Protect passwords.**

- Change the default password when you first use the device or system.
- Choose a long password (minimum 8 characters) using a mix of different letters and characters to make the password more secure and harder to hack.

## **7. Use the latest security software.**

- Install antivirus software on all computers to detect and remove viruses.
- Keep the antivirus software up to date.

## **8. Use the latest version of the device and system software.**

- Apply patches to keep the OS and applications up to date.

## **9. Monitor and detect abnormalities in the network.**

- Keep monitoring the network for any abnormalities to take a prompt measure and issue an alert if any abnormality is detected.

Install an intrusion detection system (IDS) and intrusion prevention system (IPS).

## **10. Delete data from devices when disposed of.**

- Before disposing of any IoT devices, delete stored data or physically destruct media to prevent any misuse of the data.

# 1. Safety Instructions for Functional Safety

## Purpose of this manual

This user safety manual provides information about the JXC□F step motor controller safety functions; its operating and connection elements.

For the functions and specifications not related to safety, please refer to the operating manuals in Table 0-1: Applicable products and documents.

## Validity of the user safety manual

This user safety manual is valid for the JXC□F in the version indicated in Table 0-1: Applicable products and documents, as well as for the same or later versions if replaced with the devices of the same type.

### 1.1. General safety notes



#### Risk of injury

Depending on the application, inappropriate use of the JXC□F may result in serious injury.

- Observe all the safety notes and warning instructions provided in this section and elsewhere in this user manual.

#### 1.1.1. Qualified Personnel

Within the context of this user manual, qualified personnel are persons who, because of their education, experience and instruction, and their knowledge of relevant standards, regulations, accident prevention, and service conditions, have been authorized to carry out any required operations, and who are able to recognize and avoid any possible dangers.

Furthermore, knowledge of the following topics is required:

- Components used
- Safety regulations in the field of application

In the context of the use of the product, the following operations must only be carried out by qualified personnel:

- Planning
- Configuration
- Installation, commissioning, servicing
- Maintenance, decommissioning

#### 1.1.2. Documentation

Observe all information in this user manual and the accompanying documents: see Appendix A Checklists

Always use the latest documentation for this product. Changes or additions to documentation can be found on the Internet (see: [www.smcworld.com](http://www.smcworld.com)).

#### 1.1.3. Safety of personnel and equipment

The safety of personnel and equipment can only be assured if the step motor controller is used correctly: see Section 1.4.1: Intended use.

#### **1.1.4. Error Detection**

The product will detect certain errors in the safety sub-function see [Section 11.6.1](#) for details.

#### **1.1.5. Do not carry out any repairs or modifications**

It is prohibited for the user to carry out repair work or make modifications to the motor controller unit. The housing must not be opened. The controller unit is protected against tampering by means of security labels. The security label is damaged in the event of unauthorized repairs or opening of the housing. In this case, the correct operation of the safety product can no longer be ensured, and any warranty is invalidated.

In the event of an unrecoverable error, send the product to SMC or contact SMC immediately.

#### **1.1.6. Mismatching and polarity reversal of connections**

Take care to avoid the mismatching, polarity reversal or tampering of connections.

## 1.2. Electrical safety



### Warning

#### Loss of safety function/hazardous shock currents

Incorrect installation can result in the loss of the safety function as well as hazardous shock currents.

- Observe the notes on electrical safety.
- Plan the products used and their installation in the system according to the specific requirements.

#### 1.2.1. Direct/indirect contact

Protection against direct and indirect contact according to EN61010-2-201 must be ensured for all components connected to the system. In the event of an error, hazardous voltages must not occur (single-fault tolerance).

Measures required:

- Using power supply units with safe isolation (SELV or PELV).
- Decoupling circuits, for any connection to circuits which are not SELV or PELV circuits using optocouplers, relays, and other components which meet the requirements of safe isolation.

#### 1.2.2. Power supply units for 24 V supply

Only use power supply units that are SELV or PELV according to EN 61010-2-201

Under and over voltage detection is included in this product but is separate to the safety sub-functions. Operation outside of the range 20.4 to 31.2 VDC will result in error conditions.

- Low voltage is detected on start-up and reported by an alarm.
- Overvoltage is detected at any point and reported by an alarm.

In both cases, the connected actuator is prevented from operating.

Please use a power supply unit with a current capacity of at least 1.5 times the peak power that is required by the actuator motor. Do not use a power supply unit with "inrush-current control" for the controller power supply.

#### 1.2.3. Insulation rating

When selecting the equipment, please take into consideration the transient and surge voltages, which may occur during operation.

The product is intended for use in Zone B (General Industrial Environment) as defined in EN 61131-2

The JXC□F is designed for use with connecting cables that are less than 30 m long and do not go outside of a building (see [Section 3.1: Basic Specifications](#) for different cable permitted lengths). If these requirements are not met, such as use in Zone C of EN 61131-2, then external measures must be taken to protect the unit.

## 1.3. Safety of the machine or system

The machine/system manufacturer and the operator are responsible for the safety of the machine or system and the application in which the machine or system is used.

### 1.3.1. Draw up and implement a safety concept

In order to use the JXC□F, a safety concept is required for your machine or system. This includes a hazard and risk analysis as well as a test report (checklist) for validating the safety function: see [Section 1.4: Directive and standards](#) and see

[Appendix A: Checklists](#).

The target safety integrity level (SIL according to EN 61508, SILCL according to EN 62061 or performance level and category according to EN ISO 13849-1) is ascertained on the basis of the risk analysis.

### 1.3.2. Validate hardware and parameterisation

Carry out a validation every time you make a safety-related modification to your overall system. Use your test report to ensure that:

- The safety products are connected to the correct actuators.
- The safety PLC is commissioned by a qualified engineer.

See [Section 4: Initial Setting Method](#) for some guidance.

## 1.4. Directive and standards

The standards to which the step motor controller conforms are listed in the certificate issued by the approval body and in the EU and UK declarations of conformity.

### 1.4.1. Intended use

The JXC□F is designed exclusively for use with SMC Co. stepper motor electrical actuators, within the limits of the specifications as described in [Section 0:](#)

Specifications and in accordance with the rest of this document. SMC Co. accepts no claims for liability if the equipment is used in any other way or if modifications are made to the device, even in the context of mounting and installing.

## 1.5. Abbreviations used

Table 1-1 Abbreviations for safety requirements

Abbreviation	Meaning	Standard	Example
SIL	Safety integrity level	EN 61508	SIL 2, SIL3
SILCL	SIL claim limit	EN 62061	SIL CL 3
Cat.	Category	EN ISO 13849-1	Cat. 2, Cat. 4
PL	Performance level	EN ISO 13849-1	PL d, PL e

Table 1-2 General Abbreviations

Abbreviation	Meaning
PELV	Protective extra-low voltage according to EN 61140
SELV	Separated extra-low voltage according to EN 61140



## 2. Product Outline

### 2.1. Features

#### 2.1.1. Functional Safety features outline

The controller supports the Safe Stop 1 time controlled function (SS1-t) in accordance to EN 61800-5-2. It can be used to implement a safety sub-function for the stepper motor of the electric actuator and complies with the following safety standards:

- EN 61508 up to SIL3/PLe
- EN 62061 SIL CL3
- EN ISO 13849-1 Cat3, PLe
- EN 61800-5-2

### Caution

#### **The proof test interval determines the Safety and Performance levels.**

In accordance with EN 61800-5-2:

- One test every 3 months corresponds to SIL3/PLe
- One test every 1 year corresponds to SIL2/PLd

Ensure the correct test interval is followed for the desired levels. **The feedback signal from the JXC□F must be evaluated by a higher-level Safety PLC to achieve the full safety specifications described in this manual.** If clarification is required, contact your nearest sales branch.

For more details on testing, see [Section 4: Initial Setting Method](#) and [Section 11.6.1: STO Testing and Faults](#).

In addition to the above diagnosis, periodically check that the safety functions are working.

#### **Safe State**

The safe state is provided by the Safe Torque Off (STO) sub-function. The safe state is switch off power supply and return lines to the motor.

#### **SS1-t Sub-function**

The SS1-t sub-function initiates motor deceleration and performs the Safe Torque Off (STO) sub-function after an application specific delay.

#### **STO Sub-function**

The STO sub-function prevents force-producing power from being provided to the motor. STO provides an uncontrolled stop according to stop category 0 of EN 60204-1, and prevents unexpected start-up.

Note that this does not prevent the motor from rotating due to external forces on the drive axis. To prevent rotation, additional safety measures such as locks or counterbalances must be used.

### Warning

#### **Power loss or failure of SS1-t time delay.**

In the event of a power loss or a failure of the time delay circuit which makes up part of the SS1-t functionality, SS1-t functions, such as deceleration, are lost.

The STO sub-function of SS1-t will not be lost. STO will function even if a single failure described above occurs.

In the case of a power failure, the product fails safe (enters STO) which is immediate.

In the case of a time delay circuit failure, the delay time may reduce to nearly zero and STO will be entered earlier.

Depending on the requirements, additional safety measures may be necessary.

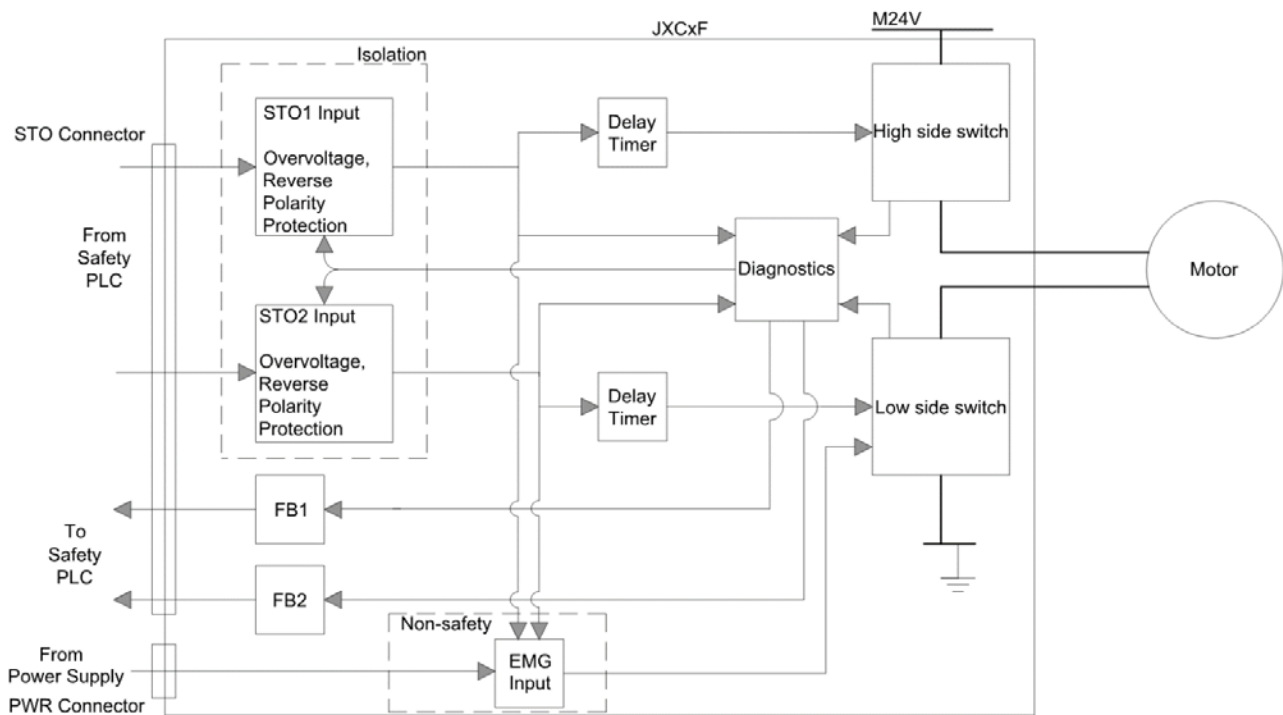

Figure 2-1: General block diagram of STO sub-function.

When the STO is demanded, the non-safety stop signal (EMG) will also be activated internally and independently.

The safety sub-function implementations are hardware based, so no software parameters are configurable in terms of safety.

### 2.1.2. STO Sub-function Residual Risks

See [Section 16: Specific Precautions for STO Sub-function.](#)

## 2.2.How to Order

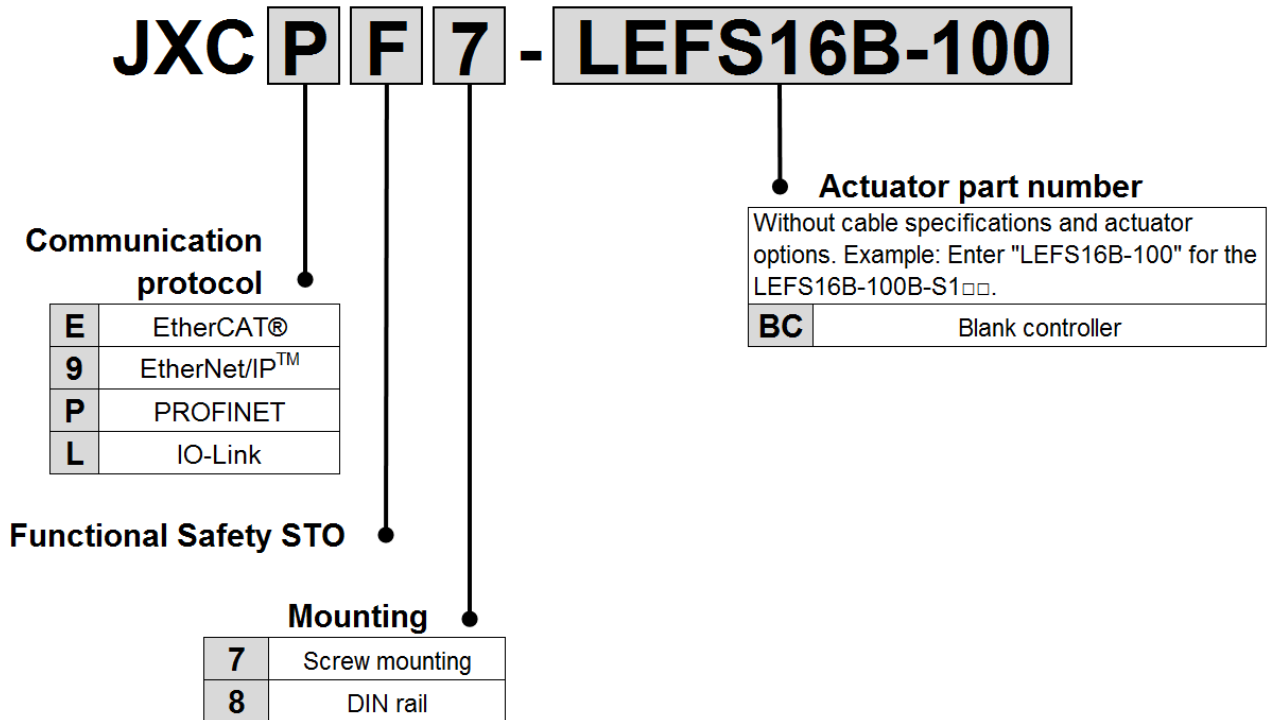

## 2.3.Product Configuration

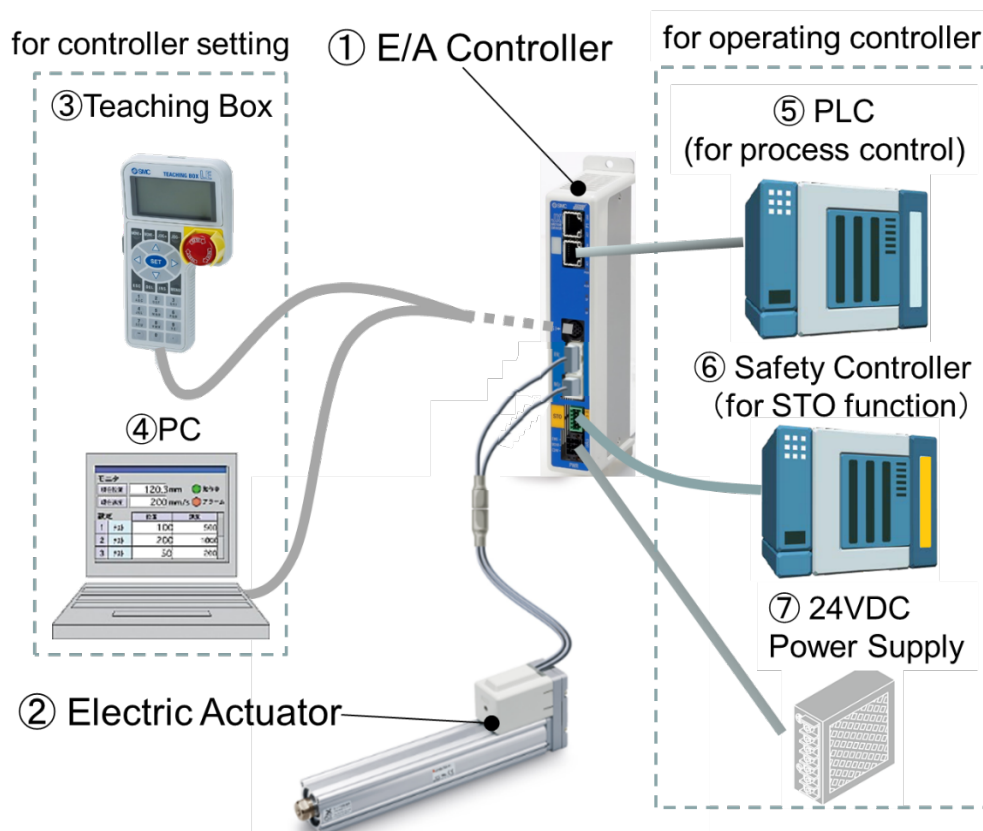

Figure 2-2: General product configuration.

For configuration of the safety related parts, please refer to [Section 3.4.2: STO STO Plug](#) and [Section 11.6: SS1-t Operation](#).

## 3. Specifications

### 3.1. Basic Specifications

Table 3-1: Basic Specifications

No.	Item	Specification	
1	Compatible motor	SMC electric actuators with stepper motor, including: Stepper motors with a typical current draw of 5 A DC or less. *1	
2	Power supply voltage (M24V, C24V)	24VDC $\pm$ 10% Certified SELV/PELV power supply required. Note – 0V of M24 and C24 is shared and common to both.	
3	Current consumption (C24V)	200 mA or less (Controller only).	
4	Output Current	Max.5A The output current to the stepping motor is not exceed 5A. *1	
5	Encoder	Incremental A/B phase (800 pulse/rotation). Battery-less absolute A/B phase (4096 pulse/rotation).	
6	LED indicator	Refer to Operation Manual of the JXC□1 series.	
7	Lock control	Lock release terminal	
8	Maximum cable length	Device	Max. Cable length
		24VDC Power Supply	30 m
		Electric Actuator	20 m
		Teaching Box	3 m
		PC	3 m
		PLC (Parallel I/O)	5 m
		PLC (Fieldbus)	30 m (depends on Fieldbus)
PLC (Safety)	30 m		
9	Cooling method	Air-cooling type	
10	Operating temperature range	0°C ~ 55°C (No freezing)	
11	Operating humidity range	90% RH or less (No condensation)	
12	Storage temperature range	-10°C ~ 60°C (No freezing)	
13	Storage humidity range	90% RH or less (No condensation)	
14	Altitude	$\leq$ 2000 m	
15	Insulation resistance	See Operation Manual of the JXC□1 series.	
16	Dimensions (W x L x H)	35 x 190 x 67 mm	
17	Weight	250g or less(Screw mounting) 270g or less(DIN rail mounting)	
18	CE Marking	Yes	
19	UKCA Marking	Yes	

Notes:

\*1) Maximum instantaneous current may be higher.

Refer to the Operation Manual of the JXC□1 series for communication specifications.  
Refer to the Declaration of Conformity (JXC9/E/P/LF-TF1Z050EU) for standards applied for CE and UKCA marking (<http://www.smcworld.com>).

Table 3-2: Protocol specific differences between STO and standard JXC□1 series.

No.	Protocol	Items	Specification JXC□F
1	PROFINET	Device ID	53h
2	EtherCAT*1	Protocol	EtherCAT (Conformance Test Record V1.2.8)
3	EtherNet/IP*2	Protocol	EtherNet/IP™ (Conformance test version CT-17)
		Product code	FFh
4	IO-Link	Product ID	JXCLF7 / JXCLF8
		Product Name	JXCLF7 / JXCLF8

Refer to the Operation Manual of the JXC□1 series for communication specifications.

\*1 : Refer to the JXC#-OMY0008 for rotary switch settings of the JXCEF only.

\*2 : Refer to the JXC#-OMY0006 for LED indicate of the JXC9F only.

## 3.2.Safety Specifications

Table 3-3: Safety Specifications

No.	Item	Specification	
1	Safety sub-function	SS1-t (EN 61800-5-2:2017)	
2	Safety Performance	Standard	Level
		EN 61508-1/2:2010	Up to SIL3/PLe
		EN 62061:2005+A2:2015	SIL CL3
		EN ISO 13849-1:2015	Cat. 3, PLe
3	Required diagnostic test interval (EN61800-5-2 , 6.2.2.1.4)	<ul style="list-style-type: none"> <li>One test every 3 months corresponds to SIL3/PLe</li> <li>One test every 1 year corresponds to SIL2/PLd</li> </ul>	
4	Mean time to dangerous failure (MTTFd) (years)	35813 (High)	
5	Hardware Fault Tolerance (HFT)	1	
6	Safe Failure Fraction (SFF)	>90%	
7	Diagnostic Coverage (DC)	>90% (Medium*3)	
8	Average probability of dangerous failures per hour (PFH <sub>d</sub> )	3.19 x 10 <sup>-9</sup> (3.19 FIT)	
9	Classification	Type A	
10	Mission time	10 (years)	

See [Section 1.5: Abbreviations used](#).

See [Section 2.1: Features](#).

See [Section 11.6.1: STO Testing and Faults](#)

\*3 : The value required by safety standards for Medium is 90-99%.

### 3.3.STO Connector Electrical Specifications

Table 3-4: STO Connector Electrical Specifications. All values DC.

No.	Item	Specification	
		Nominal	Maximum
1	STO1/2 Voltage	24 V (relative to common 0V on PWR connector)	30 V
2	STO1/2 Current (Typ)	4.2 mA	
3	STO1/2 Threshold Voltage	Logic 0 (Low)	Logic 1 (High)
		<5 V	>11 V
4	STO1/2 Protection	<ul style="list-style-type: none"> <li>• Reverse Polarity Protection</li> <li>• Withstand voltage up to 60 VDC</li> </ul>	
5	Maximum SS1-t delay	600 ms	
6	Maximum pulse width	1 ms	
7	Minimum pulse interval	40 ms	
8	24V Output maximum current	100 mA (current limited)	
9	Feedback1/2 Voltage (nominal value)	Logic 0 (Low)	Logic 1 (High)
		0 V	24 V

### 3.4.Name and function of Parts

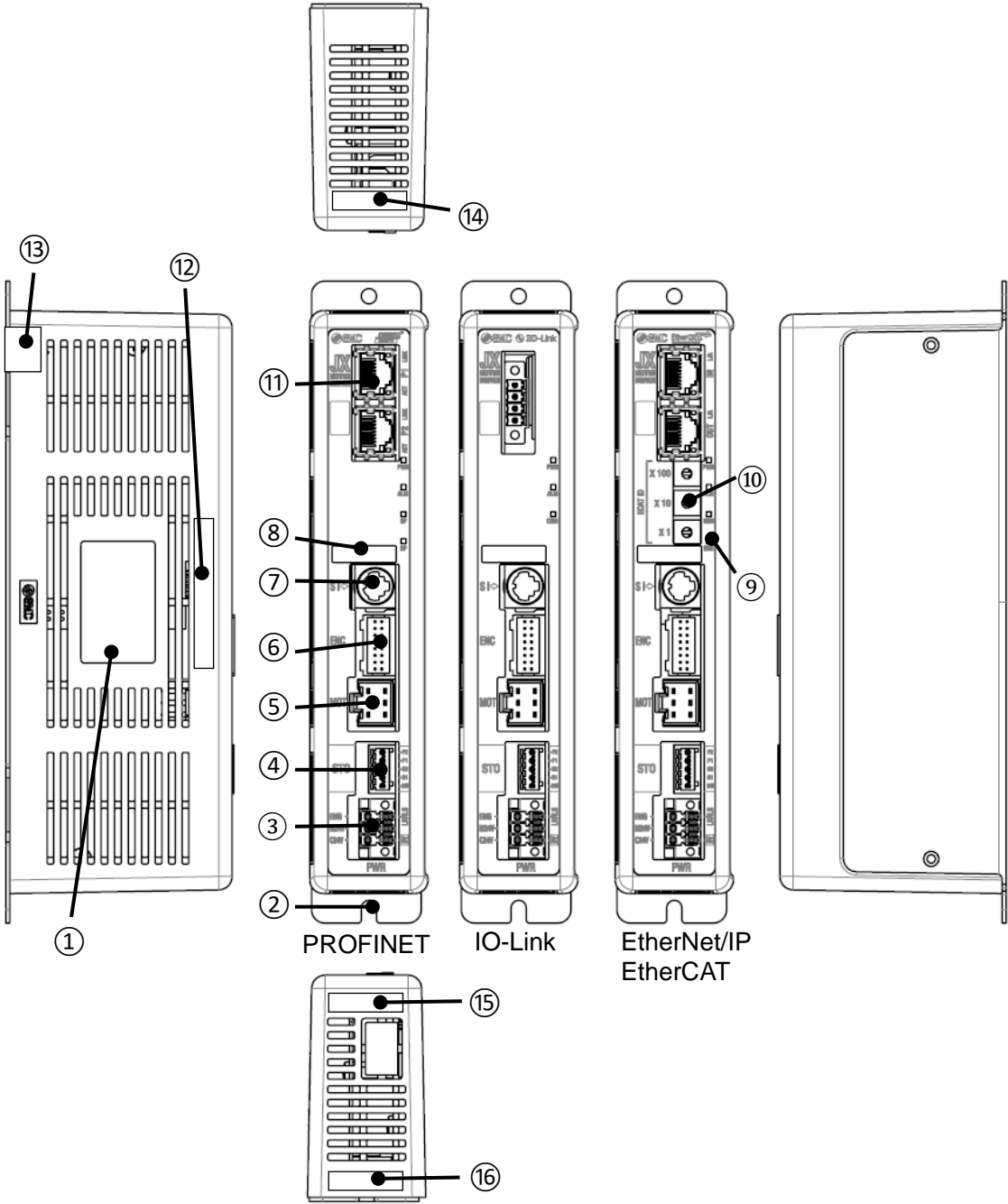

Figure 3-1: Annotation of parts on the JXC□F.

Table 3-5: Identification of controller parts.

No.	Components	Function
1	Controller part number label	Label indicating the controller part number.
2	FE	Functional Earth. When the controller is mounted, tighten screws and connect the grounding cable.
3	PWR	Power supply connector (5 poles). Connect to the controller power supply (24VDC) using the power supply plug. See <u>Section 3.4.1</u> for pin assignment of power supply plug.
4	STO	STO Connector (5 poles). Connect to the controller responsible for STO sub-function control. See <u>Section 3.4.2</u> for pin assignment of STO plug.
5	MOT	Motor driving connector (6 poles). Connect to the actuator cable.
6	ENC	Encoder connector (16 poles). Connect to the actuator cable.
7	SI	Serial I/O connector (8 poles). Connector for the teaching box (LEC-T1) or the setting communication cable (JXC-W2-C).
8	Applicable actuator part number label	Label indicating the actuator part number which can be connected to the controller.
9	LED	LEDs to indicate the controller status.
10	Rotary switch	Switches to set the address for EtherNet/IP and EtherCAT (excluding PROFINET/IO-Link).
11	Communication connector	Connector for fieldbus connection.
12	MAC Address label	Label indicating the MAC address of the product for PROFINET and EtherNet/IP (excluding IO-Link/EtherCAT).
13	Security label	Please refer to following note below.
14	Safety HW version label	Label indicating the Safety HW version.
15	Non-Safety version label	Label indicating the Non-Safety version.
16	Serial number label	Label indicating the serial number

Note : It is prohibited for the user to carry out repair work or make modifications to the controller. The housing must not be opened. The controller is protected against tampering by means of security labels. The security label is damaged in the event of unauthorized repairs or opening of the housing. In this case, the correct operation of the controller can no longer be ensured.



### 3.4.1. Power Supply Plug

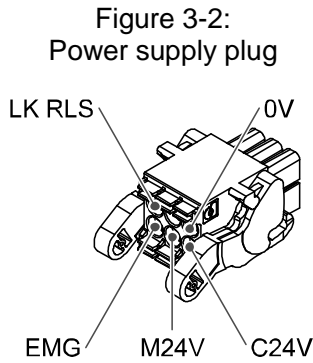

Table 3-6: Power Supply Plug Pinout

Pin No.	Terminal	Function	Functional explanation
1	C24V	Power supply (+)	The positive control power.
2	M24V	Motor power (+)	The positive power for the actuator motor to be supplied via the controller.
3	EMG	Stop (+)	The positive power for non-safety Stop signal
4	0V	Common power (-)	The negative common power for M24V, C24V, EMG and LK RLS.
5	-	NC	N/A
6	LK RLS	Unlocking (+)	The positive power for lock release.

□ Equivalent to Phoenix Contact: DFMC1, 5/3-ST-LR

### 3.4.2. STO Plug

Figure 3-3:  
STO Plug

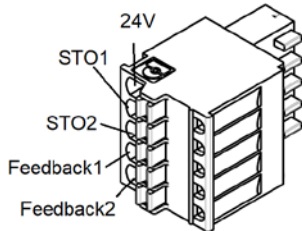

Table 3-7: STO Plug Pinout

Pin No.	Signal	Type	Description
1	24V	Output	Supply output (internally connected to C24V). Maximum output current 100 mA. Overcurrent protection.
2	STO1	Input	IEC 61131-2 Type 3 input to control STO demand on Channel 1.
3	STO2	Input	IEC 61131-2 Type 3 input to control STO demand on Channel 2.
4	Feedback1	Output	Channel 1 feedback signal.
5	Feedback2	Output	Channel 2 feedback signal.

For safety wiring information, please refer to [Section 11.6.3: STO Wiring Example](#).

### 3.4.3. Labelling

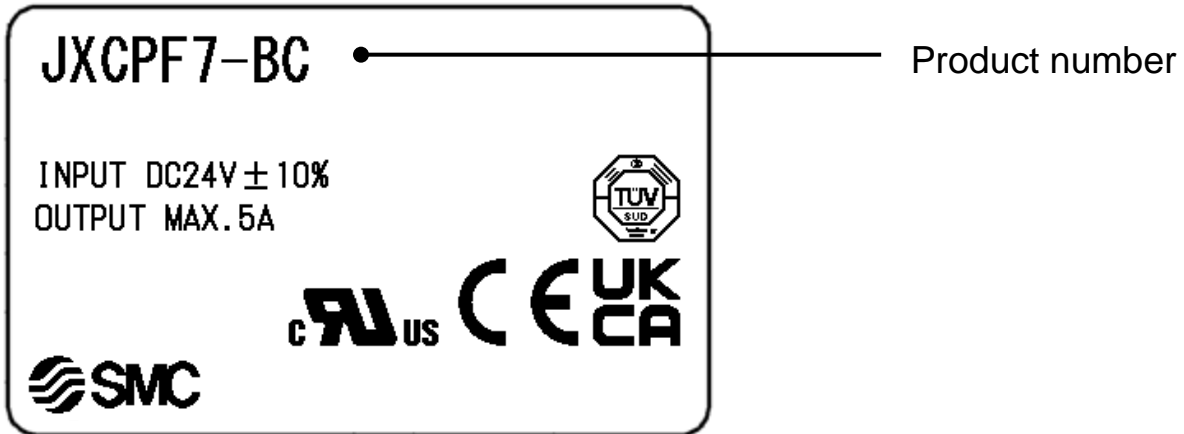
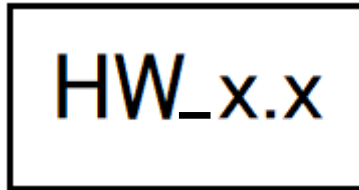

Figure 3-4 Production label



**Hardware version : 1.1 and Higher**

Figure 3-5 Safety HW version label

### 3.5.External Dimensions

The appearance of this product is as shown in the diagram below:

#### (1) Screw mounting (JXC□F7-□)

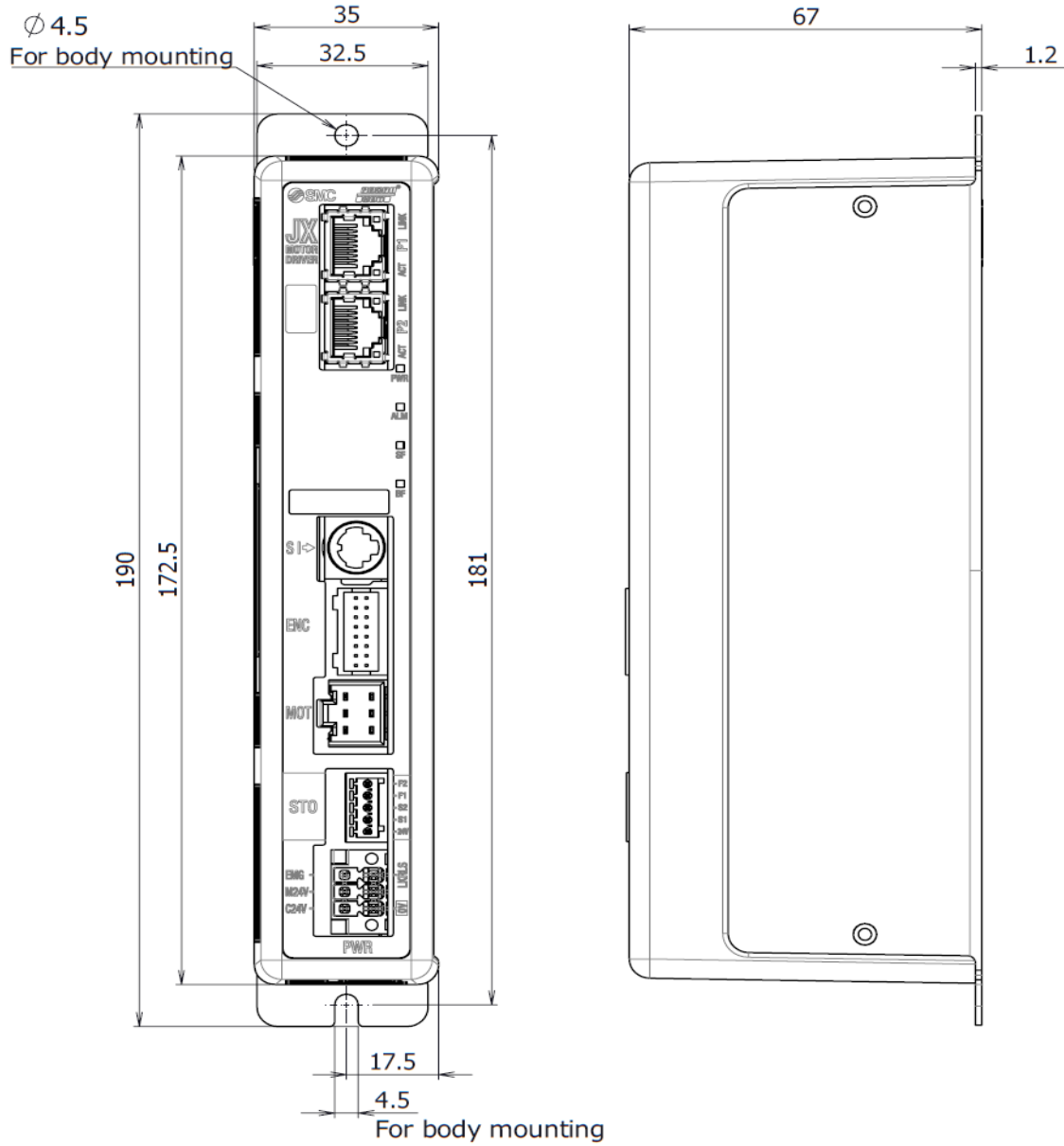

**(2) DIN rail mounting (JXC□F8-□)**

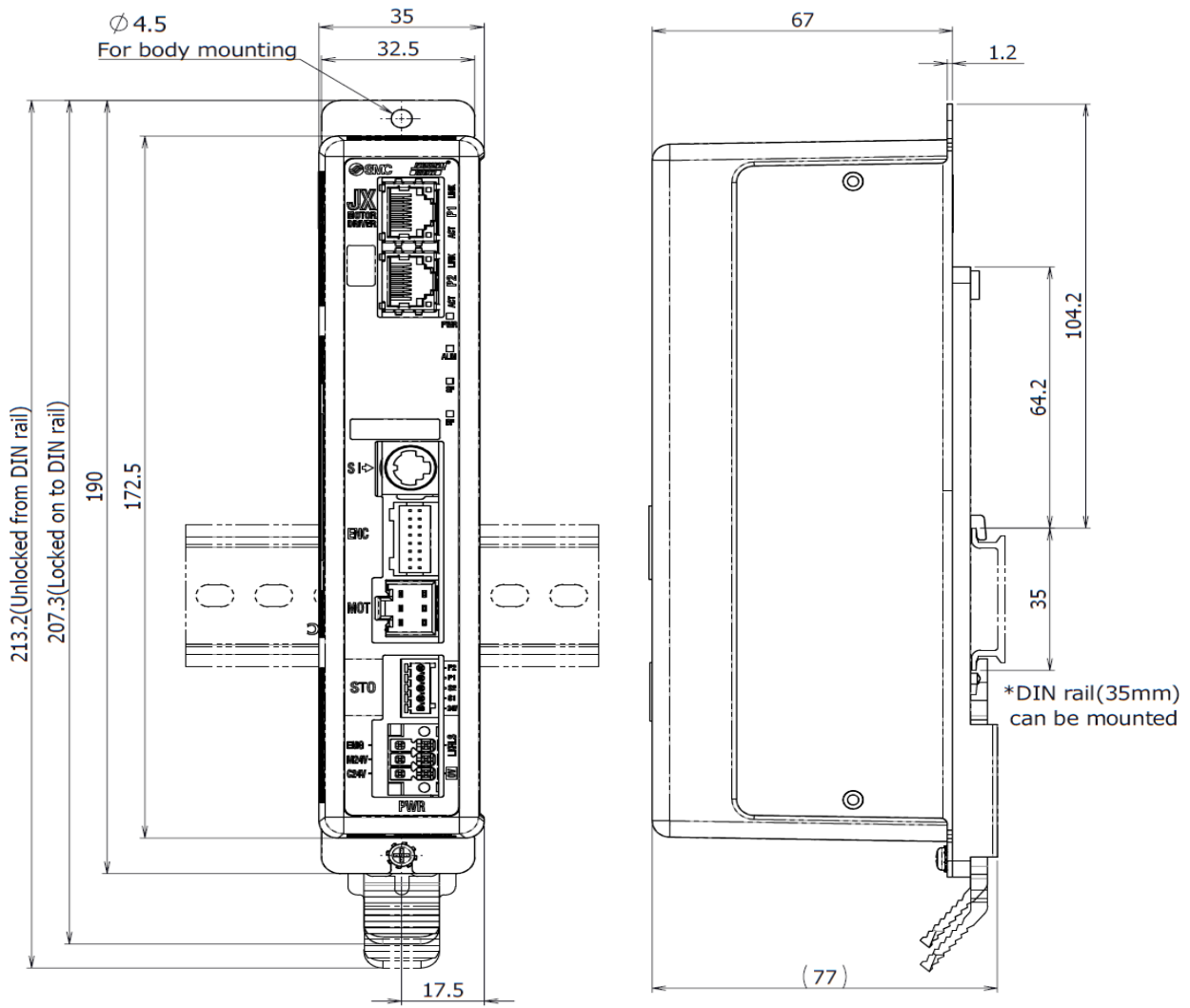

### 3.6.Mounting

For mounting, wiring and other connectors not described in this safety manual, please refer to the Operation Manual of the JXC□1 series.

## 4. Initial Setting Method

Refer to the Operation Manual of the JXC□1 series for the initial setting method not related to safety functions.

When commissioning, checking or performing maintenance on the safety circuit, ensure the following flowchart is followed before the safety circuit resumes normal operation.

The goal is to confirm the JXC□F STO operation behaves as expected, primarily using [Section 11.6.2: STO Truth Table](#) and [Section 11.6.4 STO Timing Diagram](#) with the flowchart below.

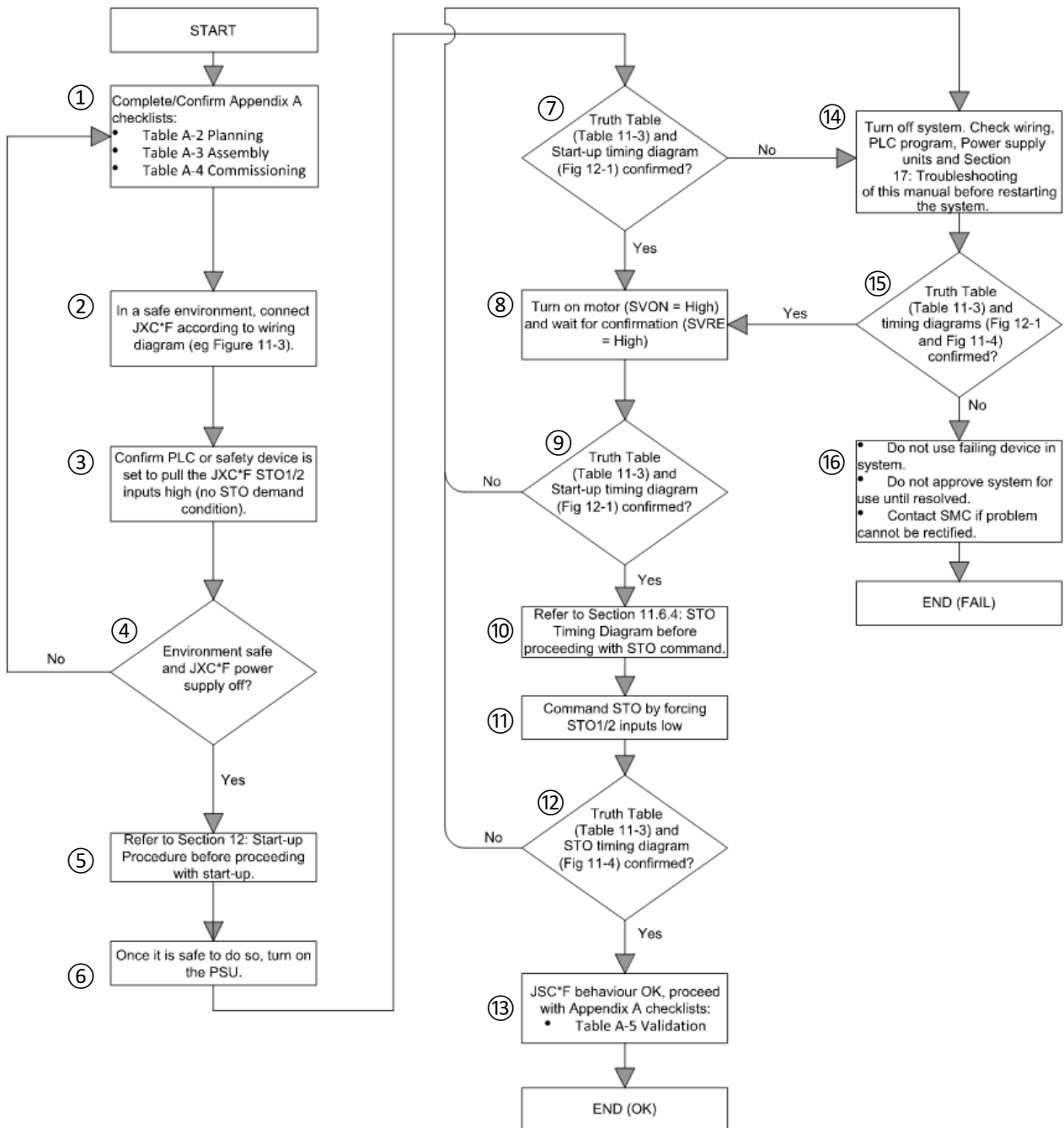

Figure 4-1: Flowchart for testing and confirming JXC□F STO operation.

### **Steps ① to ④: Safety of system and surroundings.**

These steps ensure that, before the commissioning/checking process, all planning and assembly steps have been carried out satisfactorily and the environment is safe for testing.

Flowchart [Figure 4-1](#) is a useful reference to help complete [Table A-4: Commissioning and Parameterisation checklist](#), in [Appendix A: Checklists](#).

### **Steps ⑤ to ⑨: Start-up behaviour checks.**

Refer to [Section 12: Start-Up Procedure](#) to confirm what to expect and check for when the JXC□F is powered on. STO Truth Table ([Table 11-3](#)) should be confirmed.

### **Steps ⑩ to ⑫: STO command check.**

An STO command is applied while the motor is on to test the behaviour is in accordance with [Section 11.6.4: STO Timing Diagram](#). STO Truth Table ([Table 11-3](#)) should be confirmed. The feedback signal from the JXC□F must be evaluated by external safety controller or equivalent to achieve the full safety specifications described in this manual.

If it is safe and reasonable to do so, when applying STO and confirming feedback, confirm the motor has been disconnected from the Power supply units.

## 5. External Connection

Refer to the Operation Manual of the JXC□1 series.

## 6. Power Supply Plug

Refer to the Operation Manual of the JXC□1 series.

## 7. LED Display

Refer to the Operation Manual of the JXC□1 series.

## 8. Operation Methods

Refer to the Operation Manual of the JXC□1 series.

## 9. Memory Map

Refer to the Operation Manual of the JXC□1 series.

## 10. Setting Data Entry

Refer to the Operation Manual of the JXC□1 series.

### 10.1. Step Data

Refer to the Operation Manual of the JXC□1 series.

### 10.2. Basic Parameters

Refer to the Operation Manual of the JXC□1 series.

### 10.3. Return to Origin Parameter

Refer to the Operation Manual of the JXC□1 series.

## 11. Operations

Refer to the Operation Manual of the JXC□1 series.

### 11.1. Return to Origin Position

Refer to the Operation Manual of the JXC□1 series.

### 11.2. Positioning Operation

Refer to the Operation Manual of the JXC□1 series.

### 11.3. Pushing Operation

Refer to the Operation Manual of the JXC□1 series.

### 11.4. Control input signal response time

Refer to the Operation Manual of the JXC□1 series.

### 11.5. Methods of interrupting operation

Refer to the Operation Manual of the JXC□1 series.



## 11.6. SS1-t Operation

The JXC□F features the SS1-t sub-function. When STO is demanded, the SS1-t sub-function initiates motor deceleration and after a fixed delay, performs the Safe Torque Off (STO) sub-function.

The STO sub-function can be used when power to the motor must be removed and an unexpected start up of that motor must be prevented, safely.

This may be used, for example, while the JXC□F and connected actuator (with motor) are actively in operation, or as a method to shut down just the motor for maintenance (eg; removing an obstruction) while leaving other parts of the circuits undisturbed etc.

The STO Connector includes all necessary signals for the SS1-t and STO sub-functions.

Table 11-1: STO signal state descriptions.

Pin	Signal	Type	State	
			Low (Logic 0)	High (Logic 1)
1	24V	Output	-	-
2	STO1	Input	STO on Channel 1 demanded.	STO on Channel 1 not demanded.
3	STO2	Input	STO on Channel 2 demanded.	STO on Channel 2 not demanded.
4	Feedback1	Output	No STO1 demand on Channel 1.	STO1 demanded. Channel 1 is in safe state and STO is active.
5	Feedback2	Output	No STO2 demand on Channel 2.	STO2 demanded. Channel 2 is in safe state and STO is active. <b>OR</b> Non-safety stop signal (EMG) is demanded. No safe state and STO is inactive.

STO should be demanded by using both STO1 and STO2 simultaneously.

(Note there is no discrepancy detection between STO1 and STO2 in the controller, **this must be detected by the supervisory controller see 11.6.2**)

The safety level is not impacted by connecting STO1 and STO2 together, so they are triggered by a single, appropriate, safety device.

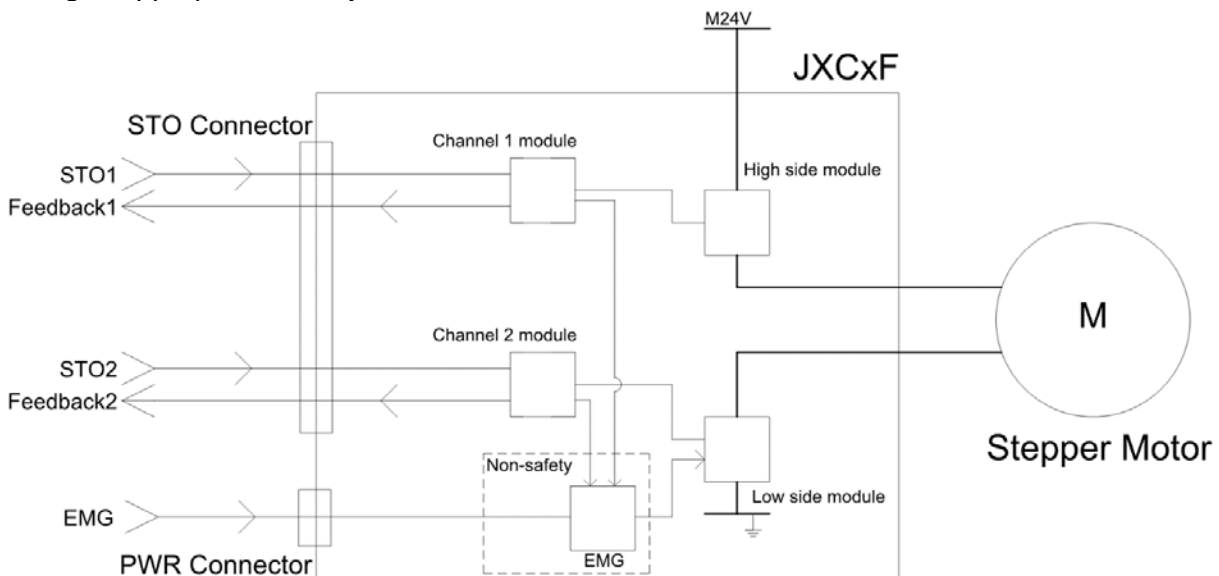

Figure 11-1: General schematic of STO sub-function

Note: When the STO is demanded, the non-safety stop signal (EMG) will also be activated internally and independently.

## 11.6.1. STO Testing and Faults

### Test pulses:

When using test pulses on the STO1/2 inputs, ensure that the pulse durations are 1 ms or less, carried out with at least 40 ms between each test pulse. (See Section 3.3: STO Connector Electrical Specifications).



### Caution

**The diagnostic test interval determines the Safety and Performance levels.**

In accordance with EN 61800-5-2:

- One test every 3 months corresponds to SIL3/PLe
- One test every 1 year corresponds to SIL2/PLd

Ensure the correct test interval is followed for the desired levels. **The feedback signal from the JXC□F must be evaluated by external safety controller or equivalent to achieve the full safety specifications described in this manual.** If clarification is required, contact your nearest sales branch.

**Diagnostic tests should entail demanding STO using STO1/2 inputs and evaluating the Feedback1/2 signals. Diagnostic test interval is on-demand. When STO applied the diagnostics are active.** In critical situations attention should be paid to overrun distances. All tests shall be overseen by qualified personnel.  
See Section 4: Initial Setting Method for guidance on testing. Testing is treated in the same way as commissioning. **The result of diagnostic test must be match the Section 11.6.2 STO Truth Table.**

In the event of a detected internal fault, the system will internally demand STO on both channels to remove power from the motor. To detect this situation, please use the Feedback1/2 signals.



### Caution

**If a fault affecting safety is detected internally, the system will enter and remain in the fail-safe state.**

Should an internal fault be detected within the JXC□F, such as a hardware component failure in the safety circuit, diagnostics will apply the safe state and power to the motor will be removed. This has the same effect as an STO demand by the user.

The safe state will remain, even if power is removed and restored. If the device remains in the safe state or clarification is required, contact your nearest sales branch.

**Do not attempt any repairs as this will compromise the safety of the system and invalidate the warranty.**

## 11.6.2. STO Truth Table

When applying an STO demand, the SS1-t sub-function initiates motor deceleration while a time delay occurs.

At the end of the time delay, STO will occur, even if the motor has not come to a complete stop. The following truth tables (Table 11-3: STO Signal Truth Table and Table 11-4: Feedback Truth Table) show the status when STO is requested while the servo motor is ON.

Table 11-2: SS1-t delay timing

Parameter	Max
Delay Time	600 ms

Table 11-3: STO Signal Truth Table

STO Input		STO Output		STO State	Description
STO1	STO2	Feedback1	Feedback2		
0	0	1	1	Active	STO demanded, power is disconnected from motor. EMG also demanded. <b>Controller is in safe state.</b>
0	1	1	1	Active	STO demanded only on Channel 1, power is disconnected from motor via high side. EMG also demanded. <b>Controller is in safe state.</b>
1	0	0	1	Active	STO demanded only on Channel 2, power is disconnected from motor via low side. EMG also demanded. <b>Controller is in safe state.</b>
1	1	0	0	Inactive	No STO demand. Motor can be powered. Normal state.

Note – where “1” is a high state, equivalent to 24VDC (nominal).

Table 11-4: Feedback Truth Table

STO Output		STO State
Feedback1	Feedback2	
1	1	Active
1	0	Active
0	1	Active
0	0	Inactive

**The feedback signal from the JXC□F must be evaluated by external safety controller or equivalent to achieve the full safety specifications described in this manual.**

**The feedback 1/2 signals should be used after the delay time in Table 11-2.**

### 11.6.3. STO Wiring Example

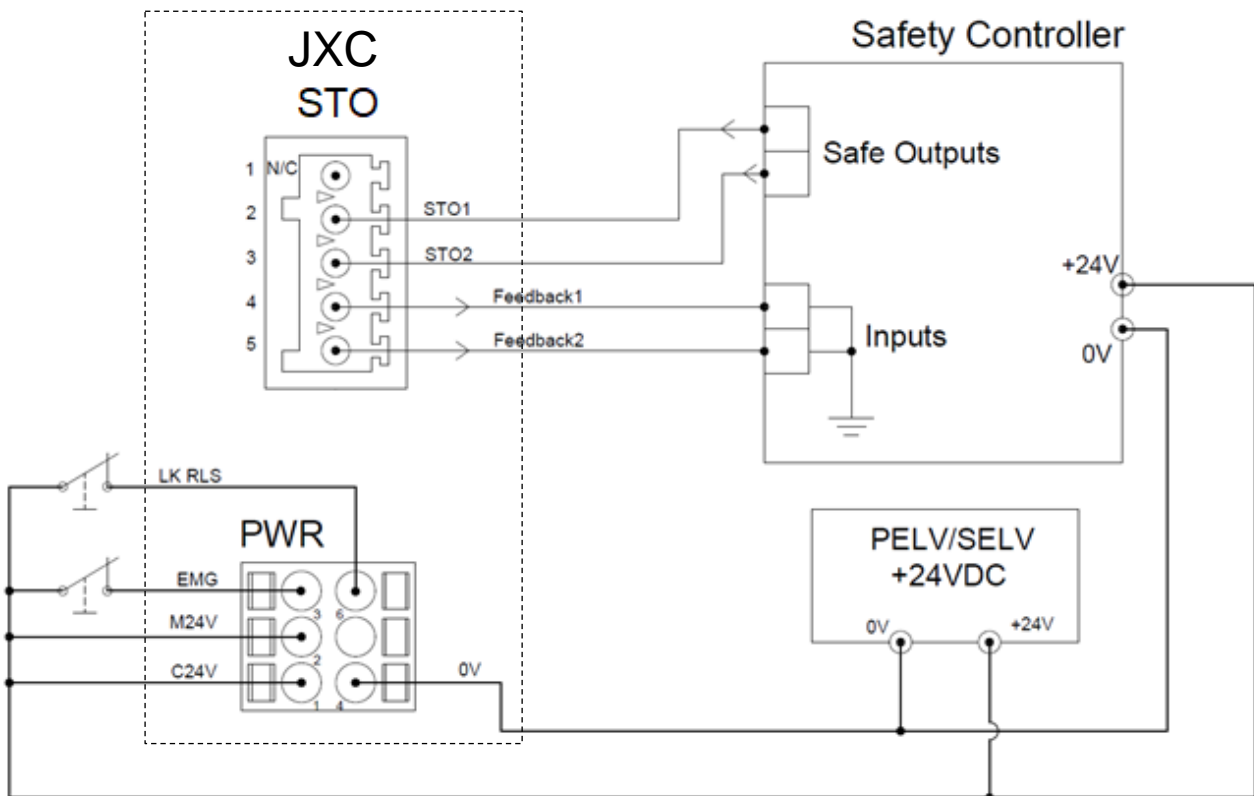

Figure 11-2: Example wiring diagram

Wiring:

When wiring the JXC□F with a safety controller, ensure both devices share a common 0V. See Figure 11-3 below for different wiring methods in the STO1/2 demand circuit.

STO1/2 inputs sink current into the JXC□1.  
 Feedback1/2 outputs source current from the JXC□1.

Signal Confirmation:

There are no alarms specifically to alert that STO has been applied. **The Feedback1/2 signals should be used for confirmation and fulfil the safety specification of this device. The feedback 1/2 signals should be used after the delay time in Table 11-2.**

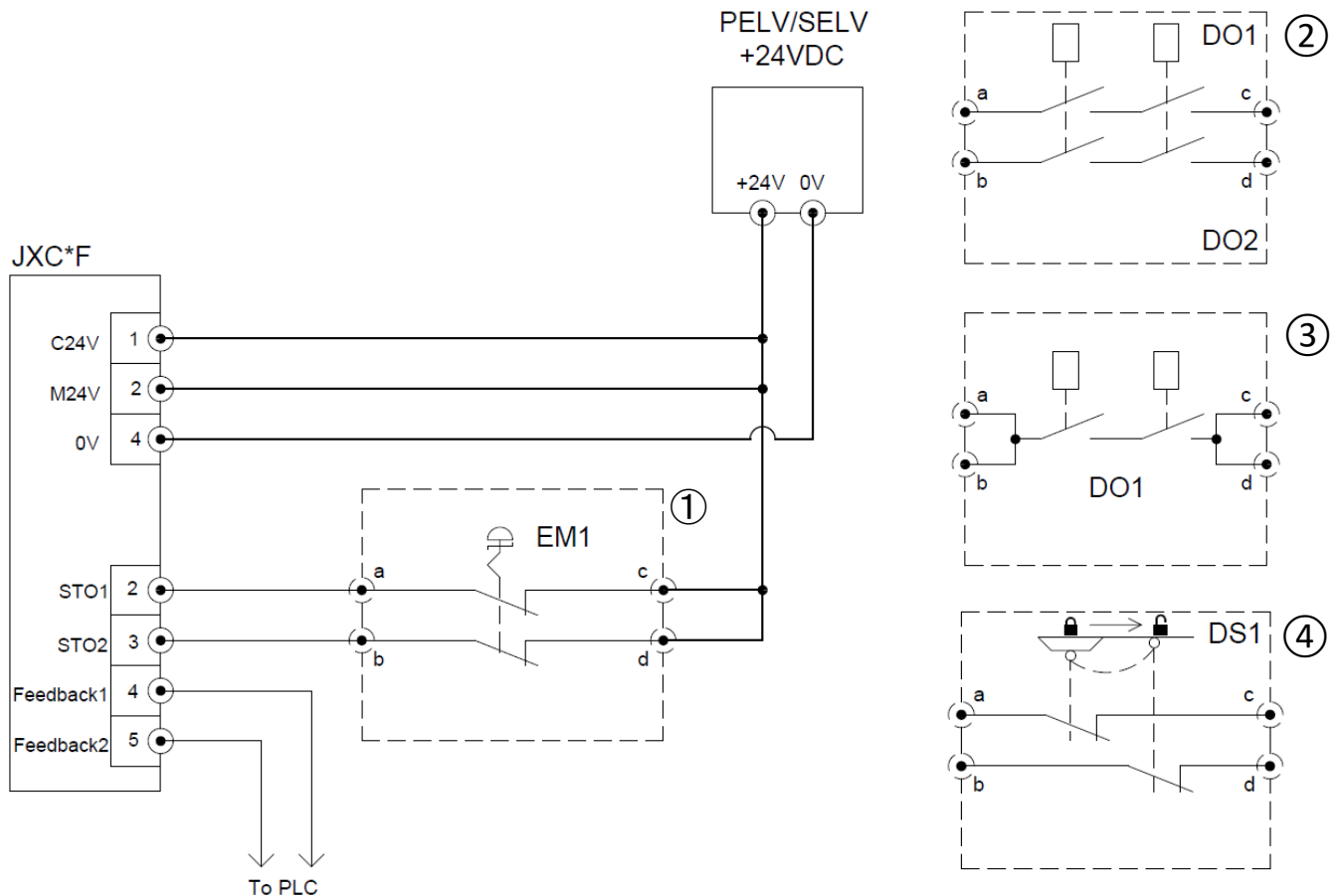

Figure 11-3: Wiring examples for different safety switch methods.

- 1) Emergency switches
- 2) Safety PLC digital outputs (with PP pulse testing)
- 3) Single safety PLC digital output (PP)
- 4) Door switch
- 5) Light curtain switch

The user should determine if the selected safety devices comply with the requirements of their application.

Note : 2) Safety PLC digital outputs (with PP pulse testing) allows individual exercising of STO1/2 and individual diagnosis of Feedback1/2. The Feedback1/2 signals should be used for confirmation.

### 11.6.4. STO Timing Diagram

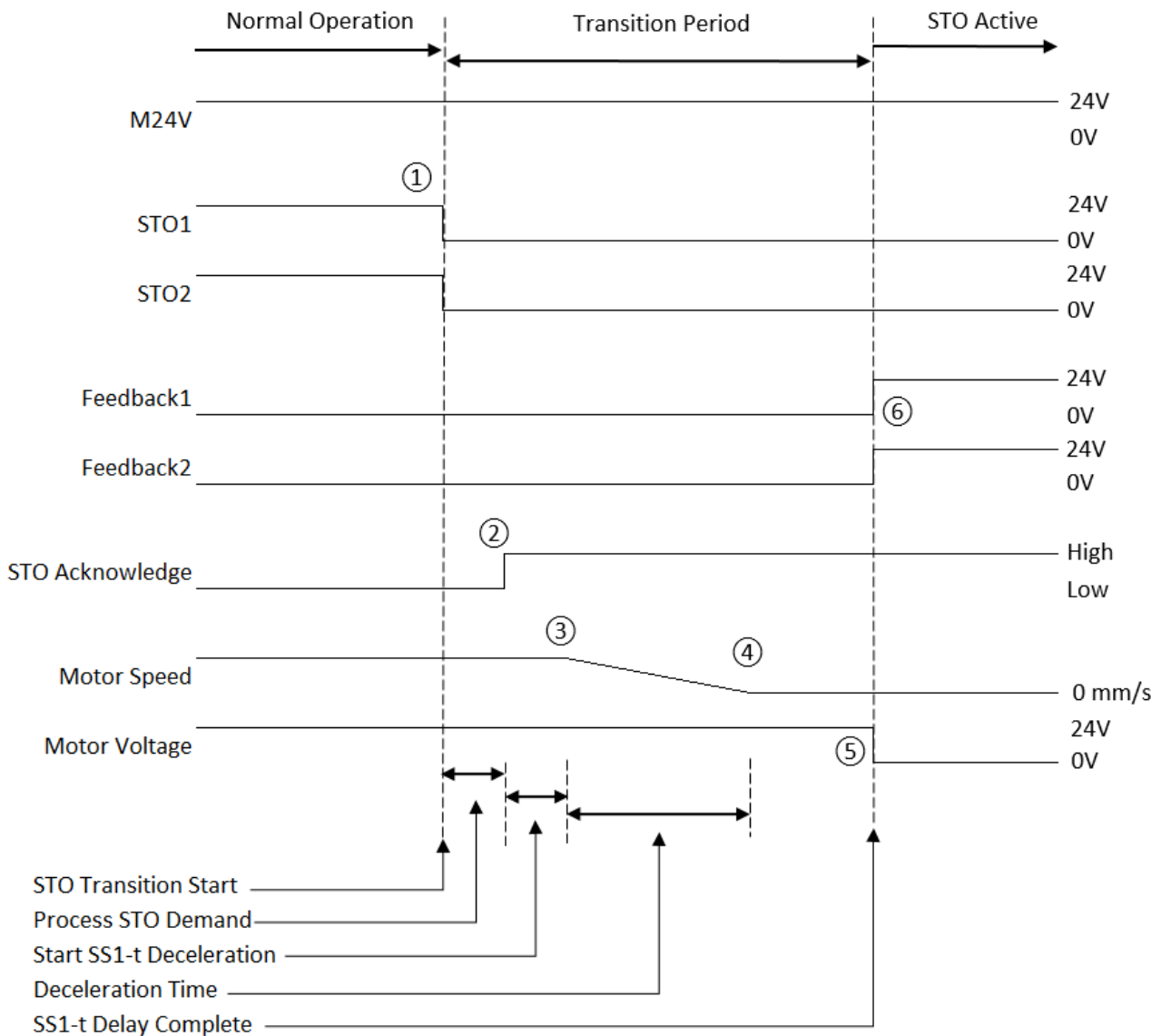

Figure 11-4: STO Timing Diagram

#### Sequence of operation:

- ① STO demand applied.
- ② Internal processing determines STO has been demanded.
- ③ Internal processing applies deceleration from SS1-t sub-function.
- ④ Motor speed reaches zero and stops.
- ⑤ Motor power is removed by cutting the M24V line within JXC□F with both high and low side switches, so the motor becomes open circuit.
- ⑥ Feedback1/2 confirm STO has been applied successfully.

Note that the Transition Period is a duration which takes up to a maximum of 600 ms according to Table 11-2: SS1-t delay timing. It is started from the moment any STO channel is demanded. Under some circumstances, such as a power failure of C24V, M24V or both, it may be possible that the SS1-t deceleration (③ → ④) does not occur within the Transition Period. Regardless, ⑤ will still occur and motor power will be removed at the end of the Transition Period to complete STO.

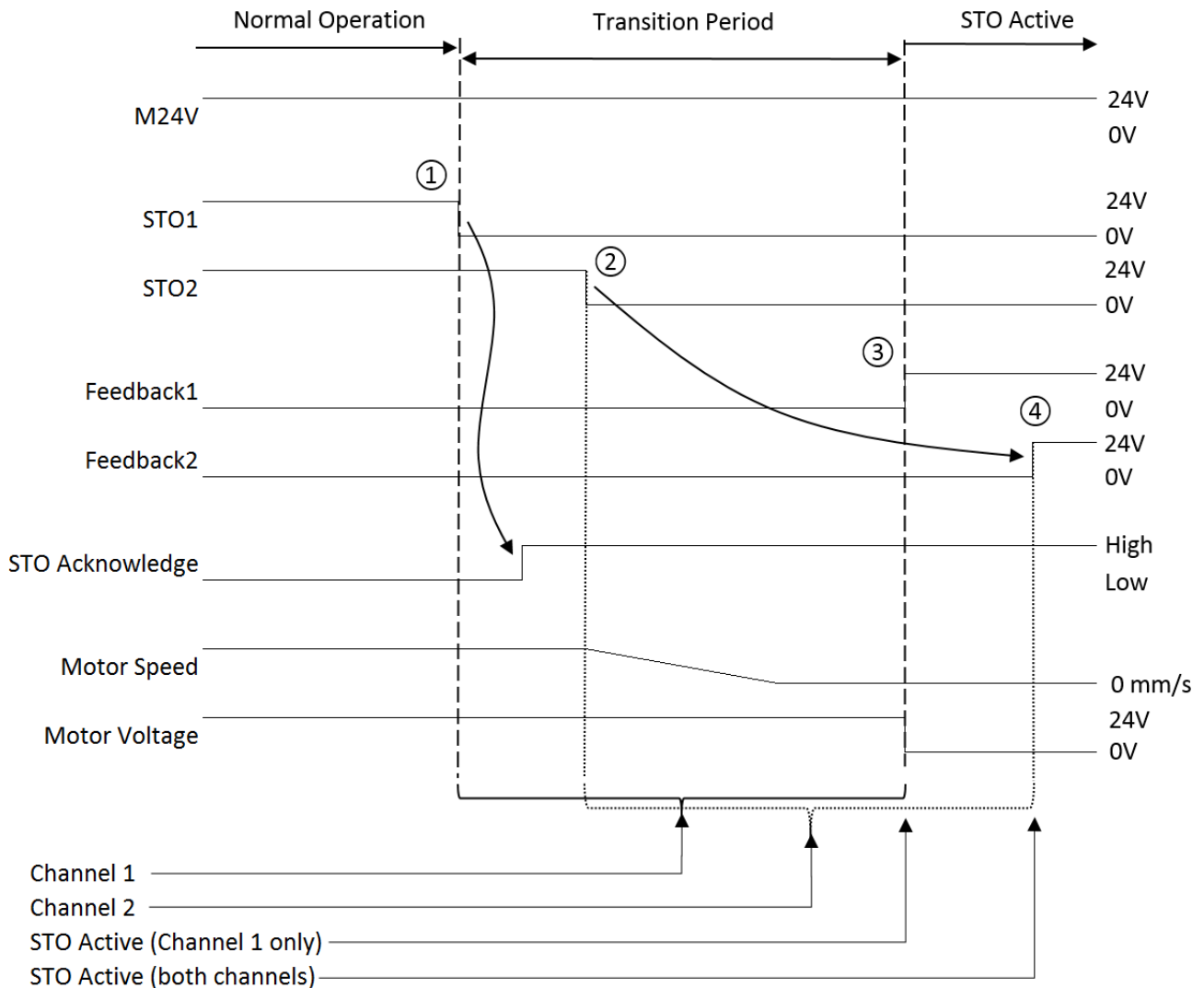

Figure 11-5: STO Timing diagram when a delay exists between STO1 and STO2 signal demands.

**Sequence of operation:**

- ① STO demand applied on Channel 1 using STO1.
- ② STO demand applied on Channel 2 using STO2.
- ③ Motor power is removed by cutting the M24V line within JXC□F on just the high side. STO on Channel 1 is active and the motor is open circuit.
- ④ The M24V line is cut on the low side (channel 2).

Feedback1 and 2 will confirm STO has been applied successfully and there will be a delay between them roughly equal to the delay in the demand.

Note that although the SS1-t delay is applied to both channels independently, the motor responds and begins decelerating in response to the first demand it receives on any STO channel. The STO state is reached after a maximum of 600 ms from a change in one of the input signals. This will only reset when all STO demand is removed.

## 12. Start-up Procedure for JXC□F with STO Sub-function

Procedure for start-up of the JXC□F with STO sub-function for every occasion when the power is applied.



### Caution

#### Correct wiring of the STO Connector is required before operation.

Wiring the STO connector for the JXC□F must be completed before powering the device on.

STO1 and STO2 must be actively held high by the supervisory safety controller in order for the JXC□F to operate normally. The following are **required**:

- STO1 input
- STO2 input

If any of these are not wired correctly, the state of the JXC□F will by default be in the safe state (STO will be demanded and therefore active). It will not be possible to operate the actuator while in the safe state.

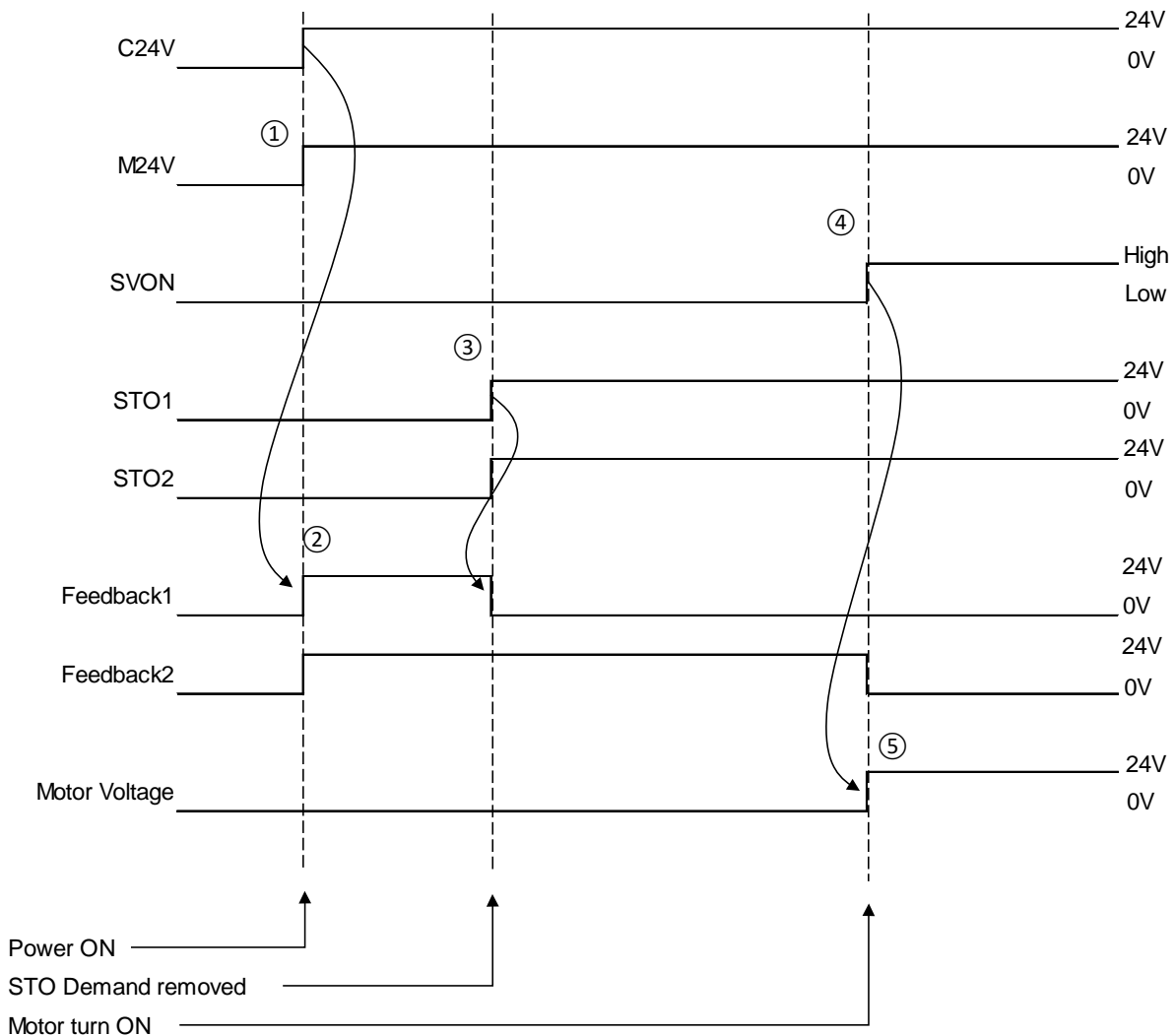

Figure 12-1: Start up timing diagram.

#### Sequence of operation:

- 1) Power supply unit turns on and power applied to M24V and C24V lines.
- 2) Feedback1/2 goes high to indicate STO demand if STO1/2 is not yet pulled high.
- 3) STO1/2 signals go high (+24VDC), causing Feedback1/2 to go low (0V).
- 4) Motor commanded to energise by making SVON signal high.
- 5) Motor voltage rises to +24VDC as circuit is powered on as soon as SVON is high.



Ensure STO1/2 are in the correct state before or at the same time power is supplied to C24V of the JXC□F.

Ensure that the STO1/2 signals are high before applying SVON, otherwise the motor will be prevented from starting due to remaining in the safe state.

Note that when power is supplied to C24V while STO1/2 input signals are still low (STO demanded), then the Feedback1/2 signals will indicate STO is applied. This remains until STO1/2 go high.

### 12.1.1. Disabling SS1-t and STO

The SS1-t and STO safety features are intended to be active and available for use by default. However, they can be intentionally disabled if the JXC□F will not be used in a safety application and may not be desired. To disable, the following 3 pins of the STO connector are connected together:

- 24V output
- STO1 input
- STO2 input

The user should determine if disabling the safety features complies with the requirements of their application.

## Warning

### **Disabling SS1-t and STO safety sub-functions**

In this state, the safety specifications described in this manual are invalid and the product is unsafe. **Do not** use this configuration in a safety application. Always use proper planning and commissioning and ensure the safety of the application complies with all safety requirements.

## 13. Operation Instructions

Refer to the Operation Manual of the JXC□1 series.

## 14. Option

Refer to the Operation Manual of the JXC□1 series.

## 15. Alarm Detection for Motor Control

Refer to the Operation Manual of the JXC□1 series.

## 16. Specific Precautions for STO Sub-function

Machine manufacturers are responsible for all risk evaluations and all associated residual risks. Below are residual risks associated with the STO sub-function. SMC is not liable for any damages or injuries caused by these risks.

- 1) The STO sub-function disables the energy supply to the motor by electrical shut-off. The sub-function does not mechanically disconnect electricity from the motor. Therefore, it cannot prevent exposure to electrical shock.
- 2) The STO sub-function does not guarantee the stop control or deceleration control of the motor.
- 3) For proper installation, wiring and adjustment, carefully read the manual of each individual safety related component.
- 4) In the safety circuit, only use components that meet the required safety standards.
- 5) The STO sub-function does not guarantee that the drive part of the motor will not rotate due to external or other forces.
- 6) Safety is not assured until all safety related components of the system are completely installed and the system has been validated by a competent person.
- 7) When replacing this motor controller, confirm the model name is exactly the same as those being replaced. Once installed, make sure to verify the performance of the safety functions before commissioning the system.
- 8) Perform all risk assessments to the machine or whole system before initial use and after any maintenance work.
- 9) To prevent accumulation of malfunctions, perform malfunction checks at regular intervals (otherwise known as the diagnostic test interval) based on the risk assessments of the machine or the system.
- 10) When using a safety PLC to connect to the JXC□F, ensure that the 0V is common between both PLC and JXC□F.

## 16.1. Misuse of SS1-t and STO Sub-functions

Foreseeable misuse of the SS1-t and STO safety sub-functions:

- 1) Use of the product outside the specifications detailed in this manual.
- 2) Bypassing the safety function.
- 3) Allowing access to the danger zone without activating the safety function. The danger zone must be inaccessible if the safety function is not activated.
- 4) Triggering other safety functions by the direct connection of the Feedback1/2 signals, including enabling access to the danger zone. The Feedback1/2 signals provide a means of improving diagnostic coverage of the STO sub-function, they are not part of the safety circuit.

## 16.2. Maintenance and Repairs

With the exception of periodic proof tests, there is no other specific maintenance agenda for the JXC□F while it is in service. Testing is described in Section 11.6.1: STO Testing and Faults.

Repairs are prohibited, see Section 1.1.5: Do not carry out any repairs or modifications.

### 16.2.1. Product Replacement

Any replacements must be of the exact same type and model. Please see Section 4: Initial Setting Method for re-commissioning, which is essential if the motor controller is replaced. The safety system must be reassessed if no exact replacement can be used.

### 16.2.2. Product Disposal

This product shall not be disposed of as municipal waste. Check your local regulations and guidelines to dispose of this product correctly, in order to reduce the impact on human health and the environment.

## 17. Troubleshooting

Table 17-1: Troubleshooting guide

No	Problem	Possible Cause	Action
1	Motor does not turn on during start-up. Alarms during start-up.	STO is active before/during motor start-up, preventing power from reaching the motor. EMG is active.	Check STO1/2 are wired correctly. Check STO1/2 signals are held high (+24V) at the same time C24V is supplied. Ensure correct wiring of EMG signal (normally high = +24V).
2	Inconsistent or delay of application of SS1-t or STO sub-functions after demand.	Signal voltage at STO1/2 inputs is in the transition region.	Ensure the input voltage signal is within Type 3 limits when the desired state is demanded (see Section 3.3). Ensure source of input voltage signal shares the same 0V as the JXC□F.
3	Incorrect or stuck Feedback1/2 signals compared to STO1/2 demand.	Excessive current draw on Feedback1/2 and/or 24V output of STO Connector causing current limiting to reduce voltage.	Ensure Feedback1/2 are wired correctly. Ensure 24V output does not have high current devices/circuits attached to it.

If any behaviour other than the above occurs, please refer to the Operation Manual of the JXC□1 series.

## 17.1. Failure Modes

The function of the product is to safely remove power from the connected motor. Hazards and harmful events that could compromise this function need to be responded to as defined below.

Table 17-2: Failure modes and actions description of JXC□F

No	Failure	Cause	Detected by	Action
1	High voltage C24V or M24V	External power supply fault	Power supply monitor circuit	Fuse blows on motor supply circuit, removing supply to motor. Turn off supply to motor by inhibiting drive signals, report by diagnostics and inhibit turn on.
2	Low voltage C24V or M24V	External power supply fault	Power supply monitor circuit	Motor inherently cannot operate at low voltage. Turn off supply to motor by inhibiting drive signals, report by diagnostics and inhibit turn on.
3	Failure of high side switch	Internal component failure	Internal safety diagnostics on- demand.	Turn off supply to motor by low side switch. Report fault by diagnostics and inhibit turn on.
4	Failure of low side switch	Internal component failure	Internal safety diagnostics on- demand. Internal current detection.	Turn off supply to motor by high side switch. Report fault by diagnostics and inhibit turn on.
5	Excess temperature	External environment condition	Temperature sensor	Turn off supply to motor by inhibiting drive signals. Report fault by diagnostics and inhibit turn on.
6	Input failure on STO1	Internal component failure while using only one input.	External safety controller comparison of STO1 and Feedback1.	Turn off supply to motor by demanding STO2 to apply STO and inhibit turn on.
	Input failure on STO2		External safety controller comparison of STO2 and Feedback2.	Turn off supply to motor by demanding STO1 to apply STO and inhibit turn on.

### In addition:

- The device goes into the fail-safe state if it detects a fault. In fail-safe state the M24V is open circuit within the device, so the motor is not supplied with power and is therefore "Off".
- The state of both a high side and low side switch module are each diagnosed constantly by hardware while the device is powered on. If a fault is detected, the redundancy mechanism is used to turn both modules off internally and achieve a fail-safe state.

## 18. Appendix A: Checklists

The checklists listed in this section provide support when carrying out the following tasks on the JXC□F: planning, assembly and electrical installation, commissioning, parameterization, and validation.

These checklists may be used as planning documentation and/or as verification to ensure the steps in the specified phases are carried out carefully.

Archive the completed checklists to use as reference for recurring tests.

The checklists do not replace the validation, initial commissioning, and regular testing performed by qualified personnel.

The following section of a checklist shows an example of a completed checklist.

Table A-1 Example of a checklist

Checklist					
Device type/equipment identification		JXC□F			
Safety HW version	1.1	Date	2021-November-1st		
Creator	John Smith	Test engineer	Jane Brown		
Remark	System XXX has been checked for engine hood production				
No.	Requirement (mandatory)		Yes		Remark
X					
No.	Requirement (Option)		Yes	No	Remark
Y					

Key:

Device type/Equipment identification:

Enter the device type and/or the equipment identification for the relevant module.

Safety HW version:

Enter the safety HW version of the module as shown on the label on the JXC□F.

For details of the label on the JXC□F, see [Section 3.4: Name and function of Parts](#).

Date:

Enter the date on which you began to fill in this checklist.

Creator:

Enter the name of the person creating this checklist.

Test engineer:

Enter the name of the test engineer.

Remark:

Enter a remark, if necessary.

Requirement (mandatory):

These requirements must be met for a safety application, in order to complete the relevant phase using the checklist.

Requirement (optional):

These requirements are optional. For points that are not met, please enter an appropriate remark in the relevant field.

Table A-2 Planning

Checklist for planning the use of the module				
Device type/equipment identification				
Safety HW version		Date		
Creator		Test engineer		
Remark				
No.	Requirement (mandatory)	Yes	Remark	
1	Has the current user manual (Safety manual/Operation manual) for this product been used as the basis for planning?		Revision:	
2	Is the selected electrical actuator approved for connection to the motor controller (according to the technical data and order options?)			
3	Has the voltage supply been planned according to the specifications for the protective extra-low voltage (PELV) or safety extra-low voltage (SELV)?			
4	Has the power supply of C24V and M24V from respective power supply units been planned?			
5	Is external protection for the module planned (according to the specifications in this user manual for supply voltage C24V and M24V)			
6	Are measures planned to prevent simple manipulation of C24V and M24V?			
7	Are measures planned to prevent connectors being mixed up?			
8	Are requirements for the actuators and cable installation specified according to the SIL/SILCL/Cat./PL to be achieved?			
9	Are test intervals specified for testing the STO motor power shutdown capability of the motor controller, if this is required to achieve a SIL/SILCL/Cat./PL?			
10	Has it been ensured that any person intentionally starting hazardous movements is limited to certain personnel (qualified or trained persons) and can only do so with a direct view of the danger zone?			
11	Does the planned use correspond to the intended use?			
12	Are the ambient conditions in conformity with the technical data?			
13	Have test intervals been defined?			
14	Has the switch-off delay for SS1-t been observed in the calculation of the total response time for the machine/system?			
No.	Requirement (optional)	Yes	No	Remark
15	Have specifications for assembly and electrical installation been defined (e.g., EPLAN) and communicated to the relevant personnel?			
16	Have specifications for commissioning been defined and communicated to the relevant personnel?			
		Date	Signature (creator)	
		Date	Signature (test engineer)	

Table A-3 Assembly and Electrical Installation

Checklist for Assembly and Electrical Installation of the module				
Device type/equipment identification				
Safety HW version		Date		
Creator		Test engineer		
Remark				
No.	Requirement (mandatory)	Yes		Remark
1	Was assembly completed according to the specifications (specifications from the planning phase or according to the user manual)?			
2	Are all connections made securely and with the correct polarity?			
3	Do the cable type sections and installation correspond to the specifications?			
4	Does the connection technology correspond to the specifications in the technical data and in the relevant user manual?			
No.	Requirement (optional)	Yes	No	Remark
5	Is the industrial Ethernet address set correctly according to the specifications?			
		Date	Signature (creator)	
		Date	Signature (test engineer)	



Table A-4 Commissioning and Parameterisation

Checklist for commissioning and parameterization of the module				
Device type/equipment identification				
Safety HW version		Date		
Creator		Test engineer		
Remark				
No.	Requirement (mandatory)	Yes		Remark
1	Was commissioning completed according to the specifications (specifications from the planning phase or according to the user manual)?			
2	During commissioning, is it ensured that any person intentionally starting hazardous movements can only do so with a direct view of the danger zone?			
No.	Requirement (optional)	Yes	No	Remark
4	Have safety distances that must be observed been calculated according to the response and delay times implemented?			
		Date		Signature(creator)
		Date		Signature (test engineer)

Table A-5 Validation

Checklist for			
Device type/equipment identification			
Safety HW version		Date	
Creator		Test engineer	
Remark			
No.	Requirement (optional)	Yes	Remark
1	Have all the mandatory requirements for the "Planning" checklist been met?		
2	Have all the mandatory requirements for the "Assembly and electrical installation" checklist been met?		
3	Have all the mandatory requirements for the "Commissioning and parameterisation" checklist been met?		
4	Does the wiring correspond to the approved wiring diagram?		
5	Has a function test been performed to check all safety functions, in which the module is involved?		
6	Have measures been taken to achieve a specific Cat.?		
7	Do all cables correspond to the specifications?		
8	Does the power supply correspond to the specifications for the protective extra-low voltage (PELV) or safety extra-low voltage (SELV)?		
9	Have the voltage supply of C24V and M24V from a power supply unit been correctly implemented?		
10	Is external protection of the module implemented (according to the specifications in this user safety manual for supply voltage C24V and M24V)?		
11	Have measures been taken to prevent simple manipulation?		
12	Are the requirements for the cable installation observed according to the SIL/SILCL/Cat./PL?		
13	Are test intervals specified for testing the shutdown capability of the actuator motor, if this is required to achieve a SIL/SILCL/Cat./PL?		
14	Has it been ensured that any person intentionally starting hazardous movements can only do so with a direct view of the danger zone?		
		Date	Signature (creator)
		Date	Signature (test engineer)

Revision history
<i>2021.August.27th : Issue</i>
<i>2021.Sep.21th : A (Contents revised in several places.)</i>
<i>2021.Nov.5th : B (Contents revised in several places.)</i>

Refer to the Declaration of Conformity (JXC9/E/P/LF--TF1Z050EU) for authorized representative under EU region (<http://www.smcworld.com>)

## SMC Corporation

4-14-1, Sotokanda, Chiyoda-ku, Tokyo 101-0021 JAPAN  
Tel: + 81 3 5207 8249 Fax: +81 3 5298 5362  
URL <http://www.smcworld.com>

---

Note: Specifications are subject to change without prior notice and any obligation on the part of the manufacturer.  
© 2021 SMC Corporation All Rights Reserved.