

Bamboo construction : Qualitative indicators for housing - Case study in Bali, Indonesia

Auteur : Mertens, Audrey

Promoteur(s) : Elsen, Catherine; Franssen, Jean-Marc

Faculté : Faculté des Sciences appliquées

Diplôme : Master en ingénieur civil architecte, à finalité spécialisée en ingénierie architecturale et urbaine

Année académique : 2018-2019

URI/URL : <http://hdl.handle.net/2268.2/8102>

Avertissement à l'attention des usagers :

Tous les documents placés en accès ouvert sur le site le site MatheO sont protégés par le droit d'auteur. Conformément aux principes énoncés par la "Budapest Open Access Initiative"(BOAI, 2002), l'utilisateur du site peut lire, télécharger, copier, transmettre, imprimer, chercher ou faire un lien vers le texte intégral de ces documents, les disséquer pour les indexer, s'en servir de données pour un logiciel, ou s'en servir à toute autre fin légale (ou prévue par la réglementation relative au droit d'auteur). Toute utilisation du document à des fins commerciales est strictement interdite.

Par ailleurs, l'utilisateur s'engage à respecter les droits moraux de l'auteur, principalement le droit à l'intégrité de l'oeuvre et le droit de paternité et ce dans toute utilisation que l'utilisateur entreprend. Ainsi, à titre d'exemple, lorsqu'il reproduira un document par extrait ou dans son intégralité, l'utilisateur citera de manière complète les sources telles que mentionnées ci-dessus. Toute utilisation non explicitement autorisée ci-avant (telle que par exemple, la modification du document ou son résumé) nécessite l'autorisation préalable et expresse des auteurs ou de leurs ayants droit.

APPENDICES

A. SURVEY FORM – ENGLISH

Survey on construction preferences

<https://docs.google.com/forms/d/1waTHKB6MWIPomhaqb3G-DXy0S-...>

Survey on construction preferences

This survey takes place as part of a research for a masters thesis in engineering and architecture. We aim to study construction practices in subtropical regions, especially Bali, Indonesia.

To begin with, we would like to know a little bit about you. Do not worry, we assure you this data will only help us in the context of a university research program.

*Obligatoire

1. I am ... *

Une seule réponse possible.

- less than 15 years old
- between 15 and 30 years old
- between 31 and 50 years old
- between 51 and 70 years old
- more than 71 years old

2. Would you mind giving your exact age below?

3. I work... (please write your field of profession or main occupation below) *

4. I live... *

Une seule réponse possible.

- alone
- with my partner
- with friends/ roommates
- with my family

5. Please enter how many you are at home : *

6. I live ... *

Une seule réponse possible.

- in Bali
- on another Indonesian island
- in another part of Asia
- Europe *Après avoir répondu à la dernière question de cette section, passez à "Thank you!".*
- Autre : _____

7. I come from ... *

Une seule réponse possible.

- in Bali
- on another Indonesian island
- in another part of Asia
- Europe *Passez à "Thank you!".*
- Autre : _____

Now, could you tell us more about your home?
Once again, this informations will only be used for research purposes!

8. If you live in Bali, could you tell us where? *

Une seule réponse possible.

- I don't live in Bali
- Denpasar
- Tabanan
- Klungkung
- Karangasem
- Jembrana
- Gianyar
- Buleleng
- Bangli
- Badung

9. Conveniences you have at home :*Plusieurs réponses possibles.*

- a kitchen (peacock)
- an indoor bathroom
- an outdoor bathroom
- a north pavilion (meten/bale naja)
- a rice attic (lumbung/fineng)
- a ceremonial pavilion (balé dangin)
- a guest-house or a west Pavilion (balé dauh/balé tiang sanga)
- a South pavilion (bale sakenam)
- Autre : _____

10. The largest part of my home is made of... **Plusieurs réponses possibles.*

- Bricks
- Concrete
- Timber/ wood
- Bamboo
- Mud/ cob/ adobe
- Steel
- Autre : _____

11. In my neighbourhood, most houses are made of... **Plusieurs réponses possibles.*

- Bricks
- Concrete
- Timber/ wood
- Bamboo
- Mud/ cob/ adobe
- Steel
- Autre : _____

12. **If you were to build a new construction at home without any kind of restriction (in terms of budget or regulations), which materials would you choose? ***

Plusieurs réponses possibles.

- Bricks
- Concrete
- Timber/ wood
- Bamboo
- Mud/ cob/ adobe
- Steel
- Autre : _____

Now, we would like to know what you think of bamboo-made houses.

13. **Name the first 3 words that come to your mind referring to bamboo: ***

14. **If you had to build an extension to your house, would you like it to be made of bamboo? ***

Une seule réponse possible.

- Yes
- No
- I don't know
- Yes, at one condition (please describe the condition below)
- Autre : _____

15. **Describe the condition:**

16. **If you wouldn't have your extension built in bamboo, explain why:**

17. If you would, which part(s) of your home would it be? *

Plusieurs réponses possibles.

- a kitchen (peacock)
- an indoor bathroom
- an outdoor bathroom
- a north pavilion (meten/bale naja)
- a rice attic (lumbung/fineng)
- a ceremonial pavilion (balé dangin)
- a guest-house or a west Pavilion (balé dauh/balé tiang sanga)
- a South pavilion (bale sakenam)
- Autre : _____

18. From your point of view, what are the pros and cons of bamboo construction :

19. From your point of view, rank by price similar size constructions (1 being the cheapest, 4 the most expensive)

Une seule réponse possible.

- Concrete structure
- Brick structure
- Timber structure
- Bamboo structure

20. From your point of view, a bamboo house lasts...

Une seule réponse possible.

- Less than 5 years
- Between 5 to 15 years
- Between 15 to 25 years
- Between 25 and 50 years
- About 50 years
- Way more than 50 years

21. **Is there, where you live, a regulation on construction which keeps you from building with bamboo?**

Une seule réponse possible.

- Yes
- No
- I don't know

22. **If so, could you tell us more about this regulation:**

23. **Do you know anyone who owns a bamboo-building?**

Une seule réponse possible.

- Yes
- No

24. **If so, what do you think about it?**

Thank you!

Thank you very much for your participation to this study. If you have anything to add to your answers or any question, feel free to contact us by e-mail : a.mertens@student.uliege.be

B. SURVEY FORM – BAHASA INDONESIA

Survei preferensi konstruksi

Survei preferensi konstruksi

Survei ini berlangsung sebagai bagian dari penelitian untuk tesis master di bidang teknik dan arsitektur.

Kami bertujuan untuk mempelajari praktik pembangunan di daerah tropis, terutama Bali, Indonesia.

Formulir ini perlu waktu sekitar 5 hingga 10 menit.

Pertama, kami ingin tahu sedikit tentang Anda.

Jangan khawatir, kami jamin data ini hanya akan membantu kami dalam konteks program penelitian universitas.

1. **Saya... ***

- kurang dari 15 tahun
- antara 15 dan 30 tahun
- antara 31 dan 50 tahun
- antara 51 dan 70 tahun
- lebih dari 71 tahun

2. **Berapa umur anda?**

3. **Silahkan tulis pekerjaan anda di bawah? ***

4. **Saya tinggal ***

- sendiri
- dengan suami atau istri
- dengan teman
- dengan keluarga
- Lain : _____

5. **Berapa orang yang tinggal di rumah anda:**

Survei preferensi konstruksi

6. Saya dari *

- Bali
 luar Bali
 Asia
 Lain : _____

7. Tinggal dimana *

- di Bali
 di luar Bali
 di Asia
 Lain : _____

Saya cari tahu lebih banyak tentang rumah anda,
Sekali lagi, informasi ini hanya akan digunakan untuk tujuan penelitian!

8. Jika Anda tinggal di Bali dimana ?

- Denpasar
 Tabanan
 Klungkung
 Karangasem
 Jembrana
 Gianyar
 Buleleng
 Bangli
 Badung
 Lain : _____

9. Saya tinggal di... *

- rumah sendiri
 rumah sewa
 rumah keluarga
 kost
 Lain : _____

Survei preferensi konstruksi

10. Di rumah anda, ada

- dapur
- kamar mandi dalam
- meten/bale naja
- lumbung/jineng
- balé dangin
- balé dauh/balé tiang sanga
- bale sakenam
- Lain : _____

11. Sebagian besar dari rumah anda terbuat: *

- Batu bata
- Beton / Concrete
- Kayu
- Bambu
- Lumpur
- Baja
- Lain : _____

12. Rata-rata rumah tetangga saya terbuat dari *

- Batu bata
- Beton / Concrete
- Kayu
- Bambu
- Lumpur
- Baja
- Lain : _____

Survei preferensi konstruksi

13. Jika anda ingin membuat rumah, material apa yang anda pilih? *

- Batu bata
- Beton / Concrete
- Kayu
- Bambu
- Lumpur
- Baja
- Lain : _____

14. Sebutkan 3 kata yang muncul pertama kali di pikiran Anda tentang rumah bambu: *

15. Jika ingin menambah bangunan rumah anda, apakah anda ingin membuatnya dari bambu?*

- Ya
- Tidak
- Tidak tahu
- Ya, kalau
- Lain : _____

16. Jika ya dengan syarat, jelaskan syaratnya

17. Jika tidak, kenapa?

Survei preferensi konstruksi

18. Jika anda ingin menggunakan bambu, bagian mana yang akan dibuat?

- dapur
- kamar mandi dalam
- meten/bale naja
- lumbung/jineng
- balé dangin
- bale dauh/bale tiang sanga
- bale sakenam
- Guest house
- hanya untuk lantai atau dinding
- hanya untuk atap
- Lain : _____

19. Dari sudut pandang Anda, apa keuntungan dan kerugian dari konstruksi bambu:

20. Dari sudut pandang Anda, berikan peringkat berdasarkan harga konstruksi dengan ukuran yang sama:

	Tidak tahu	termurah	murah	terjangkau	mahal	paling mahal
Batu bata	<input type="checkbox"/>	<input type="checkbox"/>	<input type="checkbox"/>	<input type="checkbox"/>	<input type="checkbox"/>	<input type="checkbox"/>
Beton / Concrete	<input type="checkbox"/>	<input type="checkbox"/>	<input type="checkbox"/>	<input type="checkbox"/>	<input type="checkbox"/>	<input type="checkbox"/>
Kayu	<input type="checkbox"/>	<input type="checkbox"/>	<input type="checkbox"/>	<input type="checkbox"/>	<input type="checkbox"/>	<input type="checkbox"/>
Bambu	<input type="checkbox"/>	<input type="checkbox"/>	<input type="checkbox"/>	<input type="checkbox"/>	<input type="checkbox"/>	<input type="checkbox"/>
Lumpur	<input type="checkbox"/>	<input type="checkbox"/>	<input type="checkbox"/>	<input type="checkbox"/>	<input type="checkbox"/>	<input type="checkbox"/>
Baja	<input type="checkbox"/>	<input type="checkbox"/>	<input type="checkbox"/>	<input type="checkbox"/>	<input type="checkbox"/>	<input type="checkbox"/>

21. Dari sudut pandang Anda, rumah bambu bisa bertahan berapa lama ?

- kurang dari 5 tahun
- antara 5 dan 15 tahun
- antara 15 dan 25 tahun
- antara 25 dan 50 tahun
- lebih dari 50 tahun
- Lain : _____

Survei preferensi konstruksi

22. Di mana Anda tinggal, apakah ada peraturan tentang konstruksi yang membuat Anda tidak bisa membangun dari bambu?

- Ya
 Tidak
 Tidak tahu

23. Kalau ya, jelaskan

24. Apakah Anda kenal seseorang yang memiliki bangunan bambu?

- Ya
 Tidak
 Lain : _____

25. Kalau ya, apa pendapat Anda tentang itu?

Terima kasih!

Terima kasih banyak atas partisipasi Anda dalam studi ini. Jika Anda memiliki sesuatu untuk ditambahkan ke jawaban Anda atau pertanyaan apa pun, jangan ragu untuk menghubungi kami melalui email: a.mertens@student.uliege.be

C. INTERVIEW GRIDS

C.1. IN-DEPTH INTERVIEWS OF EXPERTS

In-depth interview with the experts (engineer, architect, owner of a bamboo house)		
Reading and signature of the consent form.		
First contact, first name, place of life, age, job / occupation. Offer a drink.		
Dans quel contexte avez-vous fondé Asali? Choix du bambou? Public ciblé ? Durée de vie du matériaux ? Budget bambou traité vs. Non traité ? Budget construction de 30 à 50m ² ttc ? Comment le bambou est-il reçu par la population locale pour le projet de l'éco-village ?	What brought you to us bamboo in your projects? What kind of public do you aim? What kinds of functions for your buildings? What is the range of cost of a bamboo house?	What is your house made of? Where do you find your bamboo? Is it easy to find? Is the bamboo you use treated? Did you encounter any maintenance problems? Termites?
What is your own home here in Bali? How was it received by your neighbours?		
In your opinion, is bamboo acceptable to the Balinese population? If no, what are the drawbacks? What is the legal framework around the bamboo construction? What is the lifespan of a bamboo house ?		
Thanks & drink – End and goodbye (offer to send some news if person seems interested)		

C.2. IN-DEPTH INTERVIEWS A PRIORI

In-depth interview a priori	Focus
Description of the process. Explications of the context in which the collected data will be used. Signature of the consent form.	<i>Reassure the interviewee,</i>
First contact, first name, place of life, age, job / occupation. Offer a drink.	<i>Collect the personal information on the interviewee and try to make them comfortable,</i>
Could you tell me about your home ? How many people do you live with? → What conveniences do you have? (outdoor/indoor bathroom, kitchen, rooms etc.) What is your home made of?	<i>Their house and personal standards,</i>
Construction in Bali: what would you say is the most used construction material in Bali? What are the pros and cons of this material?	<i>Their general vision on construction material in general,</i>
If you were to build a new construction at home without any kind of restriction (in terms of	<i>Their ideal material(s) and why.</i>

budget or regulations), which materials would you choose?	
<i>Small break if necessary.</i>	
Now, if I ask you about bamboo construction, what comes to your mind first?	<i>Perception/ key words/ ideas/ clichés on bamboo construction,</i>
Would you build with bamboo?	<i>Opinion of bamboo construction,</i>
If one of your neighbours were to build in bamboo, how would you feel about that?	<i>Social acceptability of the material,</i>
What would you think is the cheapest and the most expensive amongst concrete, brick or bamboo construction?	<i>Cost perception,</i>
How long does a bamboo house last?	<i>Durability perception,</i>
Can you think of any other barrier to using bamboo as a construction material?	<i>Other criteria (negative),</i>
Can you think of any strong incentive encouraging the use of bamboo as a construction material?	<i>Other criteria (positive),</i>
What are the first thoughts that come to mind with these pictures?	<i>Photo elicitation,</i>
To sum up, could you remind me the pros and cons of bamboo construction (compared to...)?	<i>Redundancy to validate what was said or add some criteria.</i>
Thanks & drink – End and goodbye (offer to send some news if person seems interested)	

C.3. PHOTO-ELICITATION IMAGES



BAMBOO GAZEBO, TOKOPEDIA,

[HTTPS://WWW.TOKOPEDIA.COM/FASTURE/GAZEBO-BAMBU?M_ID=17019540](https://www.tokopedia.com/fasture/gazebo-bambu?M_ID=17019540)



JL BAHAY KUBO AND BAMBOO CRAFT,
PANGASINAN, PHILIPPINES, PHOTO FROM [HTTPS://TRETRUCTHIENPHUC.COM/](https://tretructhienphuc.com/)



PP HILL BAMBOO BUNGALOW, BAHAY KUBO
DESIGNS, KO PHI PHI DON, THAILANDE, PHOTO FROM [HTTPS://WWW.BEDANDBREAKFAST.EU/](https://www.bedandbreakfast.eu/)



BAMBOO HOUSE, H&P ARCHITURE,
VIETNAM, PHOTO FROM [ARCHDAILY.COM](http://archdaily.com)



BAMBOO YURT, BAMBOOU

WORKSHOP, BALI, PHOTO FROM INSTAGRAM



DD BAMBOO LODGE BALI, GIANYAR,

PHOTO FROM AIRBNB.



DD BAMBOO LODGE BALI, GIANYAR, PHOTO FROM

AIRBNB.



LE BAMBOO BALI, ULUWATU, BALI, PHOTO FROM

BOOKING.COM



GREEN VILLAGE, BY IBUKU, BALI,

PHOTO BY RIO HELMI



ECO BAMBOO HOME, BALI, PHOTO

FROM [HTTPS://MOVINGTAHITI.COM/DECORATION/LECO-BAMBOO-HOME-UNE-CABANE-TROPICALE-A-BALI/](https://movingtahiti.com/decoration/leco-bamboo-home-une-cabane-tropicale-a-bali/)



BAMBOO CABIN "PETITE COCOON",

PHOTO FROM [HTTPS://WWW.BAMBU.SA.FR/PETITE-COCOON-TOIT-BARDEAU-EN-BAMBOU.HTM](https://www.bambusa.fr/petite-cocoon-toit-bardeau-en-bamboo.htm)



PREFABRICATED BAMBOO HOUSE,

PHOTO COURTESY OF ASALI BALI



PREFABRICATED BAMBOO HOUSE,

PHOTO COURTESY OF ASALI BALI



PANYADEN SCHOOL, CHIANGMAI

LIFE CONSTRUCTION, [HTTPS://WWW.BAMBOO-EARTH-ARCHITECTURE-CONSTRUCTION.COM/PORTFOLIO-ITEM/PANYADEN-SCHOOL/](https://www.bamboo-earth-architecture-construction.com/portfolio-item/panyaden-school/)

C.4. COMMENTED WALKS

- 7- Define the instructions relating to the description and the duration of the experiment,
- 8- Re-explain the context of the study (master thesis),
- 9- Launch the cameras and the Dictaphone,
- 10- Present a scenario to the potential user: they are told to imagine that these buildings are their own. The first one is presented as an extension to their current house. What function would they like it to be for?
The second visited building is a whole new home for them.
They get to discover the spaces and are asked to explicitly comment the feelings, sensations, thoughts and opinions about it. Does it correspond to their expectations for a new building of their own?
- 11- Insist on their sensory perceptions: What do they think of the place? How do they feel? What does it smell maybe? They are asked to give a sensory feedback (visual, olfactory, sound, touched).
- 12- Return to the site if possible to identify in detail the conditions from which appear phenomena described by passers-by, reversing the relationship between observation and description: it is no longer a question of describing what one perceives but of relating the descriptions to what is observable on the spot (Thibaud, 2001).

For the sake of this research, as the owner of the house visited in the commented walks doesn't want his identity to be disclosed, his name will not be mentioned in the transcripts.

C.5. IN-DEPTH INTERVIEWS *A POSTERIORI*

In-depth interview <i>a posteriori</i>	<i>Focus</i>
How did you feel throughout the visit we just made?	<i>Get a feedback on the emotional state during the visit,</i>
Would you build with bamboo? Why?	<i>Compare with the previous answer to observe if there is an evolution in the answers (same for following questions),</i>
If one of your neighbours were to build in bamboo, how would you feel about that?	<i>Social acceptability,</i>
How long do you think a construction like this might last?	<i>Durability perception,</i>
If you changed your mind, what was the trigger?	<i>Change of perception or/and acceptance, indicator of qualitative housing,</i>
Can you think of any strong incentive encouraging or something that could stop you from using bamboo as a construction material?	<i>Other criteria,</i>
What is, in your opinion, the range of cost of bamboo construction?	<i>Cost perception,</i>
To sum up, could you remind me the pros and cons of bamboo construction (compared to...)?	<i>Redundancy to validate what was said or add some criteria.</i>
Thanks & drink – End and goodbye (offer to send some news if person seems interested)	

D. TRANSCRIPT 1 – INTERVIEW OF CHIKO WIRAHADI PURNAWAN PART 1

[00:01] Audrey: Hello again. I'd like you to present yourself shortly, your name and what you do for a living.

[00:09] Chiko: My name is Imade Wirahadi, but usually they call me Chiko Wirahadi. My main job is architect, doing some design and build but doing some specialise in bamboo or other eco-friendly material. So we have design and contractor and sometimes doing some furniture and interior design.

[00:44] Audrey: For how long have you been working with bamboo?

[00:47] Chiko: I think starting in 2005. Starting when I still work in a company. So the company is really really into the eco-friendly business. But the basic is in jewellery.

[01:13] Audrey: What's the name of the company?

[01:14] Chiko: John Hardy Jewellery. They call indah. Beautiful craftsmanship. So their basic main business is jewellery. But they are doing some building and doing some other supporting jewellery always in the eco-friendly business.

[01:43] Audrey: Why did you personally, as an architect on your own, decide to use bamboo as main construction material?

[01:54] Chiko: So in the beginning I'm not really into the architecture. So after graduate... architect in Bali is a bit hard. When they not appreciate the design process very much. They just want to see the building. So I go to construction business like building housing and some spa buildings but mostly so standard like everybody's doing like using concrete, bricks, blocks and steel. And then I get bankrupt, I get bankrupt in the beginning. So I started working when I'm still being a student. That's why I spent 7 years. It's supposed to be 4 or 5 years because I stopped doing my thesis. So I worked and doing business, that one. Some project not going well so I had to go working somewhere. Then I go submit to the one company called John Hardy Jewellery. That's four... uhh the beginning of 5 years. Five years starting doing the special project apartment. So not handling the main business but just supporting the business and doing some experiments.

[03:39] Audrey: So that is what brought you to bamboo?

[03:42] Chiko: Yes because every day we work with eco-friendly material. So we don't allow to using wood, we don't allow to using plywood, we don't allow to... It's like you go to concentration camp and you cannot do this, you cannot do that. You have to do this. It's like a brain wash.

[04:10] Audrey: And now that you work on your own, you still use bamboo as you were taught when you were working with that company? Now that you are on your own, you still use bamboo most of your projects?

[04:23] Chiko: Yes, mostly like 90% is still using bamboo.

[04:32] Audrey: Ok. What kind of public do you aim? Your clients, are they Indonesian? Are they foreigners? Are they Balinese or not?

[04:45] Chiko: Mostly mix. Some foreigners and some local.

[04:54] Audrey: Like 50-50?

[04:57] Chiko: Yes 50-50.

[04:59] Audrey: What kind of buildings do they build in bamboo? Is it more housing or commercial building or restaurants or...

[05:10] Chiko: Usually before, started more bamboo in commercial like. But in the last 3 years, they became housing. So in the beginning of... So I started my own business 7 years. So in the beginning 3 or 4 years, half of that, they still use bamboo for the front of the house but not the housing because they are still thinking about the maintenance and how long they can stay strong, the lifespan and things like that. But now in the last in 3 years, we are starting to promote some housing through... into the hospitality

business, it's working but housing more. And become after housing space, is they more receive bamboo now and starting the components like small culms and things like that.

[06:30] Audrey: You were talking about the lifespan of the material. How long would you say that is for bamboo buildings?

[06:39] Chiko: So for the standard of the treated well is like 15 to 20 years but I think still can get way more than 20 years if you're doing the maintenance during the 15 years very good. And maintenance very good and there are some special traditions of bamboo that can take more than 20 years.

[07:18] Audrey: Would you mind answering questions about the budget of these constructions?

[07:22] Chiko: Uh-uh.

[07:23] Audrey: For a small kind of construction of housing type of about 30 meter square? 30 to 40, how much would you say that costs?

[07:39] Chiko: When we are doing some budgeting, when we are talking about housing and public spaces is a bit different. Because when housing there's a lot of like walls and indoor details. Usually we but some average for public buildings 3 to 4 million per meter square and for the housing like 4 to 5 million per meter square. It depends of the spec, there is a lot of unusualness materials for the spec.

[08:16] Audrey: And now, about your own house here in Bali, what is it made of?

[08:22] Chiko: My house is made from concrete because I designed this house like 20 years ago when I'm still a student and it's a bit like tied and then I design this house it's already concrete and we used wood too, we used traditional standard Bali house material and Balinese carving and things like that.

[09:00] Audrey: And if were to build an extension to your house, which material would you choose?

[09:04] Chiko: I'm still using, thinking about not bamboo in this house because it's not fit on with the building itself. And uh the durability of the bamboo of you put in my first house it would be not matching. Maybe for some decoration like interior...

[09:34] Audrey: Ok, bamboo for...

[09:35] Chiko: Yes just like for some decoration.

[09:38] Audrey: How would you think, if someone in the neighbourhood built a house in bamboo, the neighbours would react?

[09:52] Chiko: If it's bamboo in my neighbour it would be very different from all the buildings in my neighbourhood. I think it's like surprisingly different.

[10:13] Audrey: Good surprise or bad surprise?

[10:15] Chiko: Yes good surprise.

[10:18] Audrey: Maybe some people would not like a bamboo house to be in their neighbourhood?

[10:24] Chiko: No I think in this... as long as the government give their permission, still okay.

[10:31] Audrey: Okay. About the government, are they like barriers to constructing in bamboo? Like regulation that would stop you from building in bamboo?

[10:44] Chiko: No, no, because in a statement of government there is a really strict in Bali to using local material and I think bamboo is local material. Just but might be a bit constraint for them is about the shape. That is cannot, still they cannot the shape do something about the shape is not too Balinese architecture.

[11:12] Audrey: So they would stop it if it was forms and shapes...

[11:18] Chiko: Too far from the Balinese traditional architecture.

[11:27] Audrey: So in your bamboo projects here in Bali, have you met some barriers and administration saying they don't like that shape?

[11:38] Chiko: In Bali, we don't handle the permit, usually the client is handling the permit for the bamboo.

[11:47] Audrey: And you've never had problems with that?

[11:50] Chiko: Until now no. Not yet. But there's some going to be going through. Because they put me to become one of the investors the owners, I have to be responsible too for submitting the permit. But maybe it'll be a little bit different in the shape to fit more with the Balinese.

[12:24] Audrey: Would you say that bamboo is an acceptable material for Balinese people or not?

[12:34] Chiko: Before, we used bamboo a lot. But before the people found how to treat bamboo for more long lasting, so it's only taking 2 or 3 years and then it gets rotten. But the traditional Bali house treatment, they have to dip the bamboo in the water and then it takes like 4 months to build. And then there is bamboo that became... there was a lot of problem with the hygiene, hygienic, like a lot of rats inside the bamboo and so people got sick so it becomes in their heads it's for poor people not for the rich people using concrete and fancy, fancy ceramic and things like that.

[13:36] Audrey: Would you say that that could change, the vision of bamboo as a poor material, could it change?

[13:44] Chiko: Yes, because the next generation will be more... After the grandma pass away I think nobody will say: "What kind of house is that?" "You know? After maybe the next generation. The good is there is a lot of foreigners starting that one because they already through all the fancy buildings that destroyed the earth. They are taking the mountains and cutting the mountain to get the fancy house and then they realize. And now they are using bamboo in their business and now the local people go : "Ooooh, that's fancy, is that possible? Ooooh". There's a kind of like style in Indonesia like to follow Americans, to follow Europeans it's like a lifestyle, right? To be more the fancy. If the European and American are using bamboo then ooh okay now it becomes fancy.

[14:49] Audrey: Ok good. Thank you. We'll take a 5 minutes break to drink a bit but we are more than halfway through.

E. TRANSCRIPT 2– INTERVIEW OF CHIKO WIRAHADI PURNAWAN PART 2

[00:15] Audrey: If I ask you about the three big words that come to your mind whilst talking about bamboo construction? Like if you had only three words to describe bamboo construction?

[00:30] Chiko: Words, only words? Only one word?

[00:35] Audrey: Three. Oh but you can have small phrases yes.

[00:42] Chiko: One would be local empowerment, number two sustainable and number three is uh... free design... No not free design, creativity!

[01:14] Audrey: Thank you. Now could you rank by price these three types of constructions? Which one is the cheapest, which one is the most expensive?

[01:28] Chiko: With the standard? I mean this can be very expensive but can be cheap.

[01:35] Audrey: Ok but like same size and same types of construction?

[01:39] Chiko: Ok standard. Well... [sorts out the pictures]

[01:46] Audrey: Ok this would be the rank?

[01:48] Chiko: What is the difference between this and this one?

[01:50] Audrey: These are bricks, with basically mud that you bake, and this is concrete so it's more or less cement, sand, rocks and water.

[02:05] Chiko: I think this one. One, two, three.

[02:11] Audrey: This would be most expensive or cheapest?

[02:14] Chiko: Cheapest.

[02:16] Audrey: So concrete cheapest, bamboo intermediate, and bricks the most expansive.

[Chiko asks Audrey what is in her point of view the rank. Then Chiko's assistant interrupts to say goodbye before the Nyepi holidays]

[03:09] Audrey: Now which one would you say lasts the longer, and you said this could last a lifetime but like compared to the other ones?

[03:32] Chiko: This one. Lifespan, the lowest, the highest.

[03:38] Audrey: Bamboo, bricks and concrete, concrete the longer. Now do you think that there are some criteria? I think you already almost answered before but I'm asking again. Things that could really change people, local mentality on bamboo? What would those be? To bring back value of the material for local people?

[04:13] Chiko: Sorry. Could you repeat please?

[04:14] Audrey: What would be a mind change?

[04:23] Chiko: I think if we... keep campaign about bamboo. Keeping using bamboo and things like that. To people, so now is now interesting design. In hospitality very strong about the creativity. So the creativity can accommodate by the bamboo design. The more I make some crazy things, I think they are going to accept it. Because they need something new every day, every week. They're looking something new in the world. Change is like that, in the world. So I'm keeping doing my creativity everyday making something new, I think that can be the change their minds.

[05:21] Audrey: What would you say are strong disadvantage of bamboo? What is it not good for?

[05:33] Chiko: There is still about the durability when it's outside, under the rain, under the water, like outdoor... or something like that. It's really weak.

[05:47] Audrey: If the design is good and the bamboo is protected, can you think of other disadvantages?

[05:55] Chiko: No, if it is already inside or under the roof, it will be only advantages. Now I'm still testing that bamboo, uh, there must be a way, I'm still trying something to make it strong for the outdoor. It is still it's weakness, in the outdoors.

[06:17] Audrey: Now I'm going to ask you to go through this pictures. You can choose three pictures but if you want to pick more you can. And just tell me what you think, what does the picture make you think about.

[06:35] Chiko: Every picture, we comment or...?

[06:37] Audrey: You don't have to do every picture. You can just choose three and if you want 4 or 5, you can comment them too. Is there something strong coming to you with one of the pictures, you can just comment it.

[07:04] Chiko: [goes through the pictures] These three pictures right.

[07:23] Audrey: Thank you.

[07:27] Chiko: So I like the one not all bamboo, it's combined to another material. It's very rich when it's not full bamboo, there's another material that... but still I like the one more sustainable material. This one my dream to make a connected house like ship in around the world and then just build up in like under a week or something like that and people can have a house. And that's why I chose these two.

[08:07] Audrey: Ok for prefab then?

[08:08] Chiko: Yes these houses.

[08:10] Audrey: Ok. Good, nice. Well thank you. I'm done.

[08:19] Chiko: And also for the disasters and things like that, if there's some... some... in Indonesia there's a lot of disasters, right? So this kind of building will be helpful if I have a good simple design and cheap, that can help people to get a home in like a week so government can pay me in and be helpful.

[08:45] Audrey: To sum up, can you remind me the pros and cons of bamboo? Like good sides and bad sides of bamboo? Remind the qualities and disadvantages? Wait, I'm gonna translate, I have the words here somewhere in Indonesian.

[09:50] Chiko: The advantage is faster than other constructions that I think because I don't like to be in project too long. So I like fast project. Like one year and it's just brick by brick and somethings like that. Kerugian [disadvantage in Bahasa Indonesia] is like because we have to build the chain. So that's the one: it's not, the material we cannot directly buy it at the shop, we have to prepare. Because if we stop, it cannot be stopped too long or something like that.

[10:53] Audrey: Ok that's it. We're good, thank you!

F. TRANSCRIPT 3 – INTERVIEW OF THIERRY CAYOT, FOUNDER OF ASALI BALI

[00:07] Audrey: Alors, Thierry, est-ce que tu peux rappeler ton rôle ici dans la société Asali ?

Thierry: Bien je l'ai fondée en 2003, j'ai fondé en 2003... Tu enregistres là ?

[00:17] Audrey: Oui.

Thierry: Ah d'accord ok. Je l'ai fondé en 2003 et à peu près en 2010 on a tourné vers le bambou. D'abord de la déco et puis on est arrivés très rapidement à faire de la construction, et très rapidement amené à partir de 2012 à se positionner sur des gros bâtiments en bambou.

[00:41] Audrey: Alors qu'est ce qui t'as amené au choix du bambou?

[00:21] Thierry: L'éthique. De prouver qu'on peut être une entreprise profitable et être « neutral carbon ». Essentiellement. Alors évidemment l'étude de marché était positive hein, je suis un businessman quand même avant tout. Mais c'était vraiment montrer qu'on peut... enfin bon dormir avec me conscience tranquille et plus toucher à la forêt même si avant, je ne travaillais qu'avec des meubles... enfin qu'avec des forêts plantations.

[01:11] Audrey: En bois?

Thierry: En bois, en Teck.

[01:15] Audrey: Donc ici, le contexte balinais t'a aussi influencé vers le choix du matériau ?

Thierry: Pas du tout. Enfin si parce qu'il était disponible et j'en vendais déjà en déco dans ma plateforme web, « the market place » de décoration en France avant donc on vendait déjà du bambou. Et évidemment ça m'a influencé de voir le bambou sous toutes ses formes dans les temples, tout ce qu'on peut y faire et cetera, ça a toujours été séduisant.

[01:49] Audrey: Au niveau du public ciblé par la société, est-ce que tu peux nous en dire un mot ?

Thierry: Alors du tourisme plutôt haute gamme. Heu... Olivier pourra te donner les pourcentages vraiment de nos clients l'année dernière. Je crois qu'on est à 40% tourisme haute gamme, 20% bâtiments industriels et 10% de résidentiel et le reste de la petite... des petites choses.

[02:22] Audrey: Pour le public résidentiel, c'est principalement...

Thierry: Des étrangers.

[02:31] Audrey: D'accord. Alors au niveau de la durée de vie du bambou, une fois qu'il est traité, on peut atteindre une durée de vie comme matériau de construction...

Thierry: Alors ça dépend si c'est bien conçu ou pas. Si c'est pas bien construit 5 ans, si c'est bien construit heu... « lifetime »

[02:49] Audrey: Ok d'accord. Du moment que, si on fait l'hypothèse que le design est bien conçu et que le matériau est utilisé au maximum de ses capacités...

Thierry: Et bien traité, effectivement. Sachant que les trois principaux points, il y a pas que ceux-là, il ne faut pas de contact permanent avec l'humidité comme par exemple un bambou en contact sur du ciment par terre, ou encore pire du sol et pas soleil, pas d'exposition direct au soleil. Tu peux chercher dans le bâtiment il y a un bambou qui est en exposition au soleil...

[03:22] Audrey: Par « lifetime », tu entends combien d'années ?

Thierry: Ben écoute, moi je peux te donner l'exemple du frère du grand-père de ma femme balinaise qui vient de mourir et il habitait dans une maison en bambou. Et il dit qu'elle était construite avant qu'il soit né. Il est mort à 85 ans. Et en utilisant des méthodes traditionnelles qui sont fort respectables mais sachant que ici, ce qu'on fait, c'est de rajouter de la technologie de l'ingénierie au-dessus des méthodes traditionnelles que l'on respecte fortement bien entendu.

[03:59] Audrey: Au niveau du budget pour une construction en bambou : traité vs non traité, la différence de budget elle est de à peu près combien?

Thierry: C'est impossible à répondre. Olivier te répondra des fourchettes parce que ça dépend du design, ça dépend des matériaux que tu utilises, ça dépend des finitions, ça dépend de certaines choses. Ça peut aller de 1 à 10, c'est une question difficile à répondre comme ça.

[04:25] Audrey: Donc si je te dis entre 30 et 50 mètres carrés de surface couverte ?

Thierry: Tu peux compter entre, vraiment du super basique pour nous, entre 1 million et 5 million du mètres carrés.

[04:45] Audrey: Dans quelle devise?

Thierry: Roupie, en comptant la structure, le toit, les murs. Voilà.

[04:55] Audrey: Alors maintenant Thierry, de quoi est faite ta propre habitation à Bali?

Thierry: Moi j'ai hérité d'une maison qui était déjà achetée qui était une maison balinaise, en fonction du Feng Shui balinaise, avec des tuiles et des pierres rouges balinaises et cetera. Là je viens de construire une autre maison qui... que j'ai pas pu faire tout en bambou parce qu'elle était dans un terrain, dans un terrain où il a fallu que je fasse un mur de soutènement pour retenir la terre et donc c'était pas du tout souhaitable. Donc j'ai fait juste la charpente en bambou sachant que la charpente est une excellente application pour le bambou. Ceci dit avant, pendant 10 ans, j'habitais dans une maison que j'ai construite en bois que j'ai achetée à Java, que j'ai remontée ici. J'ai complété tout le reste en bambou : les cloisons, le toit, les rafters, le plancher.

[05:55] Audrey: Et comment est-ce que ça a été reçu par tes voisins, quand tu as construit en bambou ?

Thierry: Bien ! Mes voisins... ça dépend de qui. Des voisins occidentaux, super. Les voisins balinais : perplexes. Enfin il trouve pas bien mais il ferait pas ça pour eux.

[06:19] Audrey: Donc je te pose quand même la question telle quelle: selon toi le bambou est-il acceptable ou non pour la population balinaise? Et sinon quelles sont les freins?

Thierry: Clairement non, clairement non. Et les freins sont essentiellement culturel. C'est que le bambou est considéré comme le matériau du pauvre parce que les gens qui n'avaient pas d'argent pour construire en bois ou en dur ben construisaient en bambou, et le bambou quand il est mal construit, quand il n'est pas traité et qu'il est mal construit, a une durée de vie très limitée de 4 - 5 ans. Donc c'est vraiment le..., je ne sais pas comment on dit en français, mais le « poor man material » construction. Et ça c'est culturelle, c'est très ancré. On a déjà construit pour des indonésiens des de projet en bambou mais des indonésiens de haute culture, très cultivés dont notamment un directeur d'école. On a fait une école de 50 mètres de long. Bon c'était quelqu'un qui était complètement informé et cultivé mais dans les classes moyennes par exemple dans mon village ils sont tous... Ils ne savent pas quoi répondre quand je leur montre mon toit en bambou. Ils ne comprennent pas, c'est même un notre monde pour eux. En général le bambou, si tu veux, il est utilisé dans les temples pour toutes les cérémonies pour des choses temporaires: faire des temples temporaires, faire des supports temporaires, faire des tables temporaires. Et puis à la fin de la cérémonie on jette tout.

[08:00] Audrey: Est-ce que, à ta connaissance, il y a des freins d'ordre administratif, régulation...

Thierry: Pas du tout, il n'y a pas de problème de régulation en Indonésie ce qui est un bon point pour nous.

[08:11] Audrey: Maintenant est-ce que tu penses que par l'exemple on peut faire évoluer la vision que les Indonésiens ont du matériau?

Thierry: Sur le long terme, moi j'ai mon expérience de 10 ans de faire des grands bâtiments en bambou, et c'était mon idée. C'était: Quand on montre des bâtiments qui ont 16 m de portée comme celui-ci fait en bambou ben ça commence à secouer la conscience, ça secours ce qu'on a. Donc c'est l'idée, c'est que il n'y a pas besoin de parler quand on voit des grands bâtiments en bambou comme ça. On se dit on peut faire ça en bambou ça veut dire que le bambou a quelque part des qualités. Bon, le gros frein qu'on a, c'est la durabilité. C'est-à-dire que pour des projets touristiques qui sont des projets de business, qui sont investis sur 10 ans on va dire, ça pose pas de problème. Pour les maisons d'habitation, on a eu souvent, même des occidentaux, pas

mal de refus de client sur des projets avancés parce que ils n'étaient pas sûrs de la durabilité, c'est quand même une maison. Il faut que ce soit en dur et cetera. Même chez nous il y a ce frein qui existe, je dirai encore plus chez les indos.

[09:22] Audrey: D'accord. Et alors au niveau de l'éco-village, dont il est question dans ton projet au sein de ton village, est-ce que tu peux nous en parler un petit peu?

Thierry: Alors c'est un projet qui s'appelle Sadar Wisata, c'est-à-dire le tourisme conscient, on part de loin. C'est un projet que j'ai initié auprès du maire du village qui la pris en main. On a monté un groupe, avec quelques potes, un groupe dans le sein du village avec les gens qui ont un peu de compétences, des drivers, dans le domaine du tourisme et des choses comme ça. On part vraiment de très très loin. donc c'est un projet sue lequel j'ai un support d'un ami qui est en thèse en nano-tourisme qui est en autrichien et qui m'aide à monter le master plan sur ce projet. C'est pas du tout évident, il y a des mentalité à changer, il y a différents aspects je vous avais dit que on est dans une zone qui est protégée donc on peut pas faire n'importe quoi . Protégée par le patrimoine mondial de l'humanité, les rivières de Jatiluwih, ça va jusqu'à notre village.

On a des freins de la population locale, ils ne comprennent pas. Moi, ma seule motivation sur le projet là, c'est de trouver... c'est la seule économie je dirais un peu sexy que j'ai trouvé pour, avec la culture organique que j'essaye de développer dans le village, pour qu'il y ait des emplois qui soient créés pour les jeunes dans le village et que ils ne se barrent pas tous en ville, et que cette culture qui est magnifique - culture orale vivante la nuit des temps, j'ai envie de dire - toujours entièrement vivante, ne soit pas perdue en une ou deux générations comme ça a été le cas dans certaines campagnes françaises, notamment la mienne en Bretagne.

[11:07] Audrey: D'accord. Je reviens une petite minute sur les freins par rapport au fait que il s'agit d'un site classé à l'Unesco. Est-ce que tu sais m'en dire plus sur ça?

Thierry: On ne peut pas transformer les rizières en zone constructible. Le problème, c'est que toutes les zones à peu près plates ont déjà été transformées en rizière. Et que donc il ne reste que des terrains qui sont en pente, par exemple. Bon, pas que... mais ça pose quand même des problèmes d'implantation sur le master plan niveau architecture. Maintenant sur l'architecture bambou, c'est possible. Le projet a 3 axes, il y a un axe de développer des homestays. Comment est-ce qu'on dit en français des homestays?

[11:55] Audrey: Des auberges?

Thierry: Non, non, des accueils chez l'habitant là, il y a tout un réseau en France pour ça. Bon, des homestays. Des villageois qui vont recevoir...

[12:08] Audrey: Des maisons d'hôte, des gîtes ?

Thierry: Des maisons d'hôtes voilà, des gîtes, voilà exactement des gîtes. Et alors pour ça on va faire des plans d'architecture. Un sera en bambou mais comme ils ont du bois en local, du bois de plantation en local dans toutes les forêts qui sont aménagées autour, il est possible que la solution préférée soit en bois local. Et puis surtout ils ne savent pas travailler des bambous. Et puis les artisans bambou sont quand même des... moi je suis content, au compagnon de France, ils sont quand même très qualifié et assez exigeants finalement en terme de salaire. Donc l'avantage, c'est que si ils font leur homestay avec des plans, ils sauront faire leur homestay tous seuls avec des plans en cailloux local. Après je ne pousserai pas mais je proposerai la solution bambou, ça pourrait attirer certains.

[13:09] Audrey: Et selon toi, le fait de proposer le bambou dans ce cadre-là ça pourrait aussi participer à faire évoluer les mentalités?

Thierry: Déjà ce que je fais dans le village fait évoluer les mentalités. Les gens, quand ils voient ma charpente, c'est complètement à l'opposé de ce qu'ils pensent que le bambou c'est le matériau du pauvre, tu vois ? Parce que, bon, moi je ne vis pas dans une cabane. Alors du coup, pour eux, c'est très très étonnant. Non, oui, oui, oui, oui, y a ça a étudier, à faire changer, à faire évoluer les mentalités... De là à ce qu'ils mettent du bambou dans leur maison, j'y crois pas trop. Sauf que certains mettent quand même des toits en Rafter, traditionnellement c'est vrai que ça s'applique bien.

[13:57] Audrey: Alors dernière question: il y a une certaine méfiance d'après ce que tu me dis concernant la durabilité du matériaux de la part des indonésiens. Est-ce que, à Asali, vous proposez une piste par rapport à ça, une garantie sur la durabilité ou quelque chose de style?

Thierry: Alors comme tout matériau naturel, comme tu le sais, en architecture, toute construction en matériaux naturels nécessite une maintenance. Cette maintenance, par l'ingénierie et le design, on essaie de la minimiser au minimum. Donc ce qu'on fait c'est qu'on garantit le bâtiment et cette garantie est liée à un contrat de maintenance qu'on fait nous par des visites, 2 fois par an, 3 fois par an, ça dépend des bâtiments, qui nous permettent de maintenir le bâtiment et donc de garantir la durée de vie du bambou. Donc tu vois ici c'est un bâtiment qui a déjà peut-être 5 ans. De temps en temps il y a une petite fuite. Tu vois, si on laissait la petite fuite, c'est sûr que tout le bambou avec l'eau, ça marche pas. On ne met jamais du bambou dans une salle de bain, c'est un non-sens. Il y en a qui viennent de nous demander de faire des bateaux en bambou, je leur dis d'aller voir ailleurs. Faut pas délirer non plus. Le bambou reste une herbe géante et donc n'a pas les capacités, les qualités techniques du bois, ou les mêmes que d'un mauvais bois. On gère ça parce que le matériaux a beaucoup d'autres intérêts, des capacités mécaniques par exemple en compression, en pression et cetera, sa forme, le design que cela apporte, les possibilités de design...

Donc beaucoup d'avantages en construction enfin surtout en construction dans le domaine touristique. Ceci dit il faut que ce soit extrêmement bien construit, la moindre erreur peut être catastrophique. Par exemple, avoir un bambou sur des fondations sans qu'il y ait un joint de capillarité, c'est quelque chose qui amène forcément le poteau à être pourri en 3 ans ou 4 ans, s'il est à l'extérieur, pour prendre un exemple, un petit exemple.

[16:38] Audrey: Et donc un contrat de maintenance, c'est sur une durée de combien de temps ?

Thierry: Et ben comme désire le client, c'est un an renouvelable et la garantie suit. Voilà donc c'est comme ça qu'on a fait. 1 an de maintenance 1 an de garantie, tu reconduis ton an de maintenance, on reconduit la garantie.

[16:55] Audrey: Parfait ! C'est tout ce dont j'avais besoin, merci.

G. TRANSCRIPT 4 – INTERVIEW OF PUTRA, OWNER OF A BAMBOO HOUSE IN BALI, INDONESIA

[00:01] Audrey: Can I ask you a few questions about your house?

Putra: Yeah sure.

[00:08] Audrey: Are you ok if I record you?

Putra: Oh my god. Ok.

[00:13] Audrey: It's for my studies. Where do you want to sit?

Putra: Right here.

[00:41] Audrey: My name is Audrey, I'm studying bamboo construction at school.

Putra: At ASALI.

[00:46] Audrey: Yes. And I'm writing a paper on bamboo construction. You are the only bamboo house owner that I could find.

Putra: Really?

[00:58] Audrey: Yes because it must be Balinese people.

Putra: You can see a lot of them. But I don't know...

[01:04] Audrey: Balinese owners?

Putra: Yes, it is difficult. Yes because they don't make it, they only sell it. The houses.

[01:14] Audrey: Can you remind me your name?

Putra: My name is Putra, Ketut Putra.

[01:19] Audrey: How old are you? If you don't mind saying.

Putra: I'm 36.

[01:25] Audrey: Ok you and your house is in bamboo?

Putra: Yes.

[01:29] Audrey: Is the structure in bamboo?

Putra: Uh uh.

[01:32] Audrey: So here you have bamboo as structure and you have other material? Can you tell me about it?

Putra: Yes for this houses, I like in bamboo because you know first all houses were all by bamboo. We don't use like concrete for that, my mantra is how local like people be back again like before, like 30 years ago, 40 years ago, 45 years ago, they all they use by bamboo. For example all the traditional houses in Bali, all they use by bamboo. Bamboo is really good and cheap also right? If it's not like a company open a big business, they are thinking only business. Now if they like to use all by bamboo, it is good for the good-looking. You can make a lot with imagination but also a simple house.

[02:39] Audrey: You have a business also with bamboo?

Putra: Yes.

[02:45] Audrey: Can you talk to me about it? Just a bit?

Putra: For my houses I make a model first. At least 2 years, from the model I make a real house. This is not so easy, with the ceremonies and everything, but I use hard by bamboo and hard by concrete.

[03:13] Audrey: Why do you use concrete?

Putra: Me? Because I have a small land not a big land. If the big land, all I use by bamboo. Because this side of my land, this is my uncle's land, I cannot use it. For that we cut by concrete. If we use bamboo we cannot cut for the land.

[03:36] Audrey: Where do you find your bamboo? Is it easy to find?

Putra: Very easy, from the farmers.

[03:45] Audrey: In Belega?

Putra: No in [name of a Balinese village] and Tabanan. They have a lot.

[03:54] Audrey: Do you treat the bamboo you use?

Putra: Yes. I treat bamboo, you know, by Borax. For the fast.

[04:04] Audrey: Ok now I saw your house at the back, where you have guests, there are little holes in the bamboo. Is that bamboo treated?

Putra: Yes, yes.

[04:18] Audrey: With borax?

Putra: With borax also.

[04:23] Audrey: How come it is attacked by termites?

Putra: But this is the last because that time it is not so, like normally one month you can use. But only two days for that one.

[04:39] Audrey: Ok so you have to put it in borax for one month.

Putra: Yes.

[04:42] Audrey: And you left it 2 days?

Putra: Yes.

[04:44] Audrey: Ok so not long enough?

Putra: No, not long, only two days because, you know, I need a lot more material for that.

[04:55] Audrey: Why do you think people in Bali don't use much bamboo for now?

Putra: For their houses? For those persons it is like very special, they are interested by design from outside. They imagine like: "Oh, I want a house like a concrete like this, like this, like a luxury villa".

[05:23] Audrey: Do you think that they think that bamboo is for the Poor?

Putra: Uh uh.

[05:29] Audrey: And they want luxury and they think luxury is concrete.

Putra: Yes. They don't think that with bamboo you can look nice with bamboo also. The simple, if you look natural is wood. Wood, can you imagine? Wood, until grow up, you need 100 years. With bamboo only 7 years. It's more faster with bamboo.

[06:01] Audrey: How long has your house been here? The bamboo house and the lodge.

Putra: 6 month.

[06:09] Audrey: Ok so it is very new? Only 6 months ago?

Putra: No, no, I built 3 years ago but it took 6 months.

[06:17] Audrey: Ok to build the building then.

Putra: Yes.

[06:19] Audrey: If you had to build a new house here or maybe, I don't know, if you had some more land, would you still use bamboo?

Putra: Yes I already have imagined also. I want to make a house like a plane. Like an airplane houses. Yes, airplane. I made a model there already.

[06:37] Audrey: I think I saw it at the back.

Putra: That's my dream, the second one.

[06:43] Audrey: Can you talk to me more about it?

Putra: Yes because I want to have a different style. If I like boats, I've already made it before, like a restaurant. Now like an airplane, looking nice, easier for the marketing, for the promotion also, to get the customers.

[07:05] Audrey: What do you neighbours think of the house? Your neighbours about your house in bamboo?

Putra: If they're a Western, they say: "wow. Amazing." Like that. Like Balinese it's normal.

[07:24] Audrey: Ok so they just think it is normal?

Putra: Yes this is normal for Balinese.

[07:28] Audrey: But the houses are round or not made of bamboo?

Putra: No, I'm the only one in the village.

[07:38] Audrey: When they see your house do they say they want the same?

Putra: If they are from the centre, they say "it's back to natural", they are sitting here until so many hours, but in this village there are just not interested. If they are from the centre, yes.

[08:02] Audrey: Why are they not interested?

Putra: I don't know because they lost the Patience, because you know like bamboo, bamboo is normal in Bali, it's Bamboo. For me it is different because I work in concrete I work in bamboo, I worked with John Hardy a long time ago. For that I know all houses and I know it is very good for making the houses. When I know I want to build

all my houses by bamboo. It is not all finished yet, if you're finished building all using by bamboo before...

[Putra's mother brings us coffee]

[08:38] Audrey: Thank you very much. Wait. Do you think is cheapest: brick, concrete or bamboo?

Putra: Bamboo.

[08:53] Audrey: And do you think it's also cheaper than wood?

Putra: Yes, more cheaper if the company... Like Asali, you know, it's very expensive.

[09:05] Audrey: Is very expensive, Asali, you think?

Putra: Yes, because... Are you recording?

[09:11] Audrey: Yes but it's ok I'm not going to tell Asali...

Putra: I have one project in Gili, I put my price: 3 million per meter square is a normal price. And in Asali, they put more high than me, two times or four times.

[09:32] Audrey: So did they put 9 million per meter square?

Putra: More. And they get the building. Because it's a big company, I don't know... Yes it's very expensive. Do you know the stuff on Gili air?

[09:53] Audrey: Yes, I've seen the project on Gili Air.

Putra: Before I meet with the owner. I gave him the solution, you must make the house like this, like this. 10 times I meeting with him.

[10:06] Audrey: And how expensive is concrete construction per meter square here?

Putra: For the concrete here, if you want like a luxury villa it is very expensive.

[10:16] Audrey: And for a normal Balinese house?

Putra: For a normal Balinese, 5 million per meter square. For the bamboo if it's me I can make 1 million per metre square. It is more cheap you know because for the material it is not so expensive, if you can do the treatments that by yourself, If you buy it already. For the bamboo, only this bamboo, if you buy it to the farmer it is very cheap, it's cheap, not the same, like 55.

[10:49] Audrey: And to treat it, to treat the bamboo, how expensive is it?

Putra: Enough for the treatment you just buy borax only 1 million.

[11:01] Audrey: How much bamboo can you treat with that?

Putra: Huh... Because you know you put only one time, and then put again put again. It is not lost, it's not the treatment. If you're good for the pole also. You just protect the water.

[11:24] Audrey: How much bamboo can you put in the same water?

Putra: More than 2000.

[11:28] Audrey: 2000 poles?

Putra: Yes. A lot of poles.

[11:35] Audrey: Do you think of anything that would bring people to use bamboo or that could stop them from using bamboo?

Putra: I can bring them.

[11:47] Audrey: You? Ha ha. No but I mean maybe... Do Mindsets need to change? Or maybe more companies should use bamboo? Do you think of anything that could help? Or do you think of something that would stop people from using it? Maybe if there is an earthquake and bamboo houses fall?

Putra: It never Falls because they follow the gravity also. They never falling down if the construction is light. If it's not, if you use like a bamboo... Until now, I did hear like a bamboo house fall. It's not going to fall.

[12:31] Audrey: Ok, thank you very much.

Putra: You're welcome !

H. TRANSCRIPT 5 – CONFERENCE BY ELORA HARDY ON THE 16/04/19, IN SEMINYAK, BALI, INDONESIA

[Conference – transcript of the parts relevant for the study]

[07:15] Maybe beauty is essential, maybe there's something critical in there. (...)

[07:25] It's just a show off but it creates possibilities. And what I've seen it create is a promise, it's a promise to the kids of a bountiful future.

[07:47] A team of artisans, architects, designers, I found myself leading a team of 130 people and as it turned out it was beyond that, a whole new industry was in motion. You don't sell reliably treated bamboo at the hardware store. So we have had to harvest trees and process them before we could even get to building. Sometimes we look out there to see what other bamboo we can buy for a project, but we cannot necessarily count on it. At the moment we still have to treat our raw material to be sure. And they don't teach how to design with bamboo in architecture school, so it's our process of learning it together and teaching each other. And it has been this adventure as a team together, we have had just enough skills and flexibility and grip to

make it happen over 80 structures in 8 years most of them here in Bali, but also around the world. (...)

[09:26] In the absence of a proper and true vocabulary of bamboo architecture or engineering, over the past 15 years, this team who is still my team now, has really had to invent our own rules and hold ourselves accountable and design our own process. (...)

[10:02] We'll design the house very often to fit in these existing contours of the land, no bulldozers, no level. These are the foundations of 6 storey house. We build light on the land whenever possible, respecting it.

[10:18] These long legs will flex shift long before they crack under the pressure of any earthquake. (...)

[12:46] The question that we are really chasing is how do we as humans with our soft skin and vulnerabilities, how can we add comfortable places for ourselves to be in the beauty of nature without harming it. So often we do this offensively, often we impose an idea from another place into the nature that we chose which is a paradox because we often chose the site because we love it. (...)

[16:08] And of course we also all need shelter. But what it seems is that somewhere along the way we have the default come to shut ourselves off. When we could expect to adjust the exact temperature in the room with a thermostat on the wall or a remote control, that convenience is really seductive and it feels good. It is a feeling of power and control and in some situations, some climates, it is absolutely necessary I can't deny that. But when it becomes a way of thinking, when it becomes the automatic, this defensive protectiveness, it's at the point where it is at the expense of the future, we all are seeing that. But not only that, it's a at the expense of your experience of the present moment.

[17:05] These are the kids at Sharma Springs, it is the morning, there is the mist, they feel it on their skin. The light is beginning to play through the space. There's some breeze, there is something about what the air around us can give us if we let it in that can add so much. But to step out of the protective shell, to get out of the defensive mode, you kind of need to know that you are going to get more back than the control that you're giving up. So it's about moments of light, it's about moments of feeling. Humans and other natural thing, we aren't made of so many right angles and straight lines. What are we surrounding ourselves with? (...)

[18:04] (our clients) have a hunger for connection that is much greater than their concern about a few ants wandering by. And what they get back, what makes it worth it, what I see is the sense of joy sometimes even the sense of wonder. And it comes down back to the little things: a sense of texture and the energy that you get from encountering textured surfaces. The first step of your day onto soft warm bamboo wood under bare feet. The first step of a life, what does that do to you? How does that wire your brain?

[19:28] And then it is also very useful because it is lightweight, with the tensile strength of steel and the compressive strength of concrete. It is all so long: up to 18 m of usable length. There is a lot of possibilities in 18 meters. There's a lot of floors.

[19:48] And seriously from simple huts to elaborate bridges, like this one in Java, bamboo has already been in quite sophisticated uses across the tropical regions of the world, for literally tens of thousands of years. We did not discover this plant. There are islands, even continents, that were likely first reached by bamboo rafts. But until recently it was almost impossible to reliably protect it insects. Even today there are a lot of bamboo building on this island that have little holes in them. The powder hole beetle is getting in there and eating them up. And for that reason, just about everything that was ever built in history from bamboo, just about everything is gone. And that is because unprotected bamboo weathers, untreated bamboo gets eaten to dust. But more importantly, that is why most people in the world, especially in tropical regions where bamboo grows, feel that you couldn't be poor enough or ignorant enough to actually consider living in a bamboo House. We started to change their mind. This go back to having learnt how to treat our bamboo with a natural salt called Borax first introduced to us by Linda Garland, which allows us to build permanent structures that will last as long as a well-cared-for wooden house could. And the problem is, there are several problems, but the main one is that we are designing for curving, tapering, hollow poles, no two poles alike, no straight lines, no "two by four"s here, and sometimes I confess I dream of "two by four"s plywood. Those of you who are architects will be digesting this and getting this: there is no straight lines ! And none of us can say that they are experts in bamboo, there is so much to learn. There are people in my team have more experience in this than anyone in the world and we are humble all the time. All that what we can do is try to grow quickly like bamboo. We strive to be flexible, we talked about this a lot. How can we be flexible enough to do bamboo justice? Some of our architects have actually said that they feel like they need to unlearn a lot of what they were trained in in order to be able to get their heads around doing what we do and doing it well, and doing it differently, finding the right ways to do it for this material. So we question constantly. (...)

[29:46] So when Autodesk showed up, a few years ago, wanting to free these fans and study our handmade structures. They wanted to test the machines that they'd been developing on our buildings. I have to say I was a little apprehensive at first. All these equipment sizing up and measuring our handmade homes. But I couldn't deny how interesting it was that these, that the technology that we couldn't quite bend to our needs, that they would want to come and study us. So they used cutting edge technology to data capture what they called our rugged terrain and they didn't mean the land they meant the building. (...) They also scanned the scale model and they compared it. (...) But that attention to detail was not lost on the final structure, this blew them away, even though it was replicated on site truly by hand. To me that was a given, the whole point. We had to take the structural model and then build it as closely

as possible. It was interesting because these guys, who created the cutting edge technologies which are opening up so many possibilities in design, very often driving design in new directions, I was so excited to hear them say that we had influenced them that we had inspired them to honour craftsmanship and tradition, and to think about bringing technologies that could support and not always drive design.

[31:03] So what is clear is that change is inevitable, our impact on the world is inevitable. We see it all around us all the time. But is it possible to make that impact positive so that human presence could add value to how we live with nature as a part of nature. (...)

[32:12] And what we see coming out of it all is that they are a lot of things we need in the world. Beyond beautiful fanciful structures, what we are really going to need to do is to house millions of people and this is not the way to do that, I'm not pretending that it is, but I hope that it is shining a light and opening the box, opening Pandora's Box, on a way to begin, a way to think about it. When we are going to need to redesign how we make buildings and objects and medicines and so many things and we are going to have to do it with materials that won't run out on us, and even more so with ways of thinking that are new and flexible and future proof. So I wonder what other materials are out there that are sustainable, regenerative the way that bamboo is, or can be reused indefinitely or be grown effortlessly. The design challenge of that is fantastic. The design process are thinking about what you're working with and how it can be valuable in different ways over periods of time without downgrading. There is so much that can happen from the scale of a human mind and design capabilities. And as the happens what I feel we need to do is to start aspiring to scarcity and stop stressing about scarcity but rather reach in for bounty and seeking out abundance. We can build a building out of poles that didn't exist four years ago that grew from sunlight and rainwater. If we can do that, there's a lot that's possible. We need to seek out abundance and inspire aspiration in this thing that we are calling sustainability. (...)

[Question 1: Does bamboo need a special treatment or maintenance to last longer here in Bali?]

You can think about it as being pretty much equivalent to a wooden house. to be designed properly to begin with to protect it from the insects and then it's designed smartly to protect it from the UV and that the engineering is all done well, you can expect a properly built bamboo house to last as long as a properly built wooden house. And they are wooden houses that are hundreds of years. we haven't had the chance to prove this in bamboo you haven't had decades or centuries yet. But it will last as well as wood when planned for. You also ask about maintenance: the maintenance is also quite similar to wood. Every few years you need to recoat it and the coating that were using at the moment are coatings very similar to what we use on wood. In the future I see that all expanding and enhancing quite dramatically because I believe the innovation of coatings will continue to accelerate and will be able to link up and use really durable long lasting coating on bamboo that we can count on. But right now

you can really only count on it for a couple of years. there's a lot of interior cosmetics for the finishing that can be done but the key is to recoat the exposed zones every few years. And in the future, those innovations and technology and different types of coatings will allow us to design very different shapes. Right now we have the style overhanging roofs, and that's a lovely stylistic thing, but it is also a practical protecting thing. That way, the possibilities will open up when we don't have to protect it when we can protected with a coating instead of a roof.

[Question 2: In your lifetime, have you seen a change in the way the see and accept the material?]

Well it's definitely being accepted as a business opportunity there are a lot of teams out there working with bamboo and taking it very seriously in that way, so I definitely see that. They don't see it like people building their homes and villages out of if again, they are still remembering their grandmother's home that wasn't able to last as long because it wasn't properly treated. but I also see a future for that. It just takes some time and it also takes cost efficiencies, which hasn't happened yet. And it takes design innovation to be thinking in that direction so there's a lot possible there.

[Question 3: As a designer and an architect, if you had the power to change one thing in Bali, what would it be?]

Oddly, because we are working very much outside of any system of regulations, it disappoints me that there isn't a bigger system in place that's guiding what's allowed to be built. Because there's so many irresponsible decisions. When we have an earthquake, there will be so much tragedy, because there hasn't been a way of, from what I understand happens on in certain parts of the world, of you know requiring people to have, builder to have smart choices and integrity around the material that they're using and the structural techniques. And as much as it's amazing to have this space to innovate that we have because no one is stopping us and no one is guiding us from governmental perspective in terms of like regulating how we are doing our engineering, that all on us. We have to be accountable as designers and architects and figure that out for ourselves and think about engineering and be responsible for our clients. In other parts of the world that is being really regarded by a bigger body, and I think that is what it would take for Bali to be like: "Oh, you just can't, it doesn't matter how much you'd pay me, you just can't there, in that situation you cannot build with that material" and just putting some brakes on it, because it's a really random thing and it is hard to watch.

[Questions 4 and 5 concern other matter, bamboo in specific fields, not relevant for this master thesis]

[Question 6: I want to know how you engineer the bamboo? Because with conventional material, the structural engineer can check if the material's strong enough]

Well similarly you need an engineer properties of the material they need to do some tests to get familiar with the strengths to be counting on. But because the material is so variable, they basically have to assume that every pole in the building behaves like the weakest pole that they've ever measured, and then they count for that. And so I suspect that when people look in time at our buildings, they will see that they are outrageously over engineered but I am very happy that they to do that in the meantime. It is all based on the same process of measuring and qualifying and you have to take into account the flexion, there is a lot of flexibility. [With bamboo, you don't have standard as with steel or concrete] No, they have to observe and measure, they have to research in order to be able to consider engineering for bamboo. So people that we work with have to have that background and then also they have to recognize her unique and different the pole is, and in some cases I've heard bamboo... I've heard engineers speak in the most inspired ways about the properties of the

material, the shape and the way structural form is designed really tends to impress engineers when they come to study it. It is often compared to carbon fibres. In certain ways you can compress like concrete, you can have tensile strength as in steel, but overall there something apparently about carbon fibres that is the most similar. What is the most I know but they get really excited and politic about it.

[Question 7: Considering the material and the labour, it seems that this might take more labour than an average concrete building. What is this like from a cost analysis perspective. Is it more expensive than to use this materials, considering the labour and the costs of raw materials or more expensive?]

It is more expensive. We are able to usually charge something similar to what it would be in another material. There is a little bit of balancing that happens because the raw material is very affordable but it has to go through so many hands in order to be properly treated and dried and prepared and crafted that by the end of it, we've only been able to succeed because we've been able to add value in the design sense and people appreciate it, it catches just people's hearts and our clients has embraced it as a luxury product. But the price is actually higher for building a high end conventional villa versus a bamboo villa although we've been able to keep it parallel. But it is much much more work. There're many more design hours and it is a lot of craftsmanship hours.

Another question was how we were planning to make it accessible for a lot of people. Well, I don't know. Is that my job? Maybe it is. I'd love to be involved in that. I'd love it, I'd love to be a part of a movement that'd make bamboo super accessible. Right now my responsibility is to try to take this plant form and this team and the possibilities of where we've taken it and just push that as far as I can. And what I'm proud about that, in the bigger picture, is that this has opened up so many people's minds to accept it or to consider it. And I think it's probably more likely that we'll inspire someone to figure that out, someone who has complementary skills. People ask me that a lot at bamboo U. While people come to bamboo U and ask like: "Wait, how do we make this affordable?" and I'm like: "I don't know, how are you gonna do? Let's figure it out!"

But right now it's like clients, projects, responsibilities, it's like the normal stuff of a business and that's what we're focused on as a team.

I. TRANSCRIPT 6 – IN-DEPTH INTERVIEW OF AYU SIMPANI, ACCOUNTER AT ASALI BALI

[00:03] Audrey: I will ask a couple of questions. You can eat of course. Answer as much as you can in English. If you don't how to say it in English, you can say it in Bahasa Indonesia. I will translate afterwards.

Could you remind us your name? What it your name?

Ayu: Ayu Simpani

[00:28] Audrey: Where do you live?

Ayu: In Gianyar

[00:35] Audrey: How old are you?

Ayu: Sorry?

[00:38] Audrey: How old, your age?

Ayu: 30 years old

[00:46] Audrey: What is your profession? Your job?

Ayu: Accounting

[00:50] Audrey: You work at asali bali, so you work in a bamboo firm?

Ayu: Yes

[00:55] Audrey: How long have you been working there?

Ayu: 2 years

[01:02] Audrey: Could you tell us a bit about your house? Your Home? Your house? Your rumah?

What is it made of? The materials? Materials?

Ayu: My house material from concrete, wood and the roof from tile.

[01:34] Audrey: Do you live alone or with your family?

Ayu: I live alone.

[01:40] Audrey: Do you have a bathroom, a kitchen? How many rooms do you have at home?

Ayu: The number of rooms in my house: four. One... One kitchen and one bathroom.

[02:07] Audrey: What would you say it the most used material in Bali? What it mostly used?

Ayu: The material in Bali the most used is concrete and wood. And "Bata", do you know "Bata"? [Indonesian]

[02:35] Audrey: Ok, I'll look it up after. Why do you think everybody uses concrete? Why? [FTR: Bata = Brick]

Ayu: Because concrete it's more... like... maybe... hum... up for "fiveteen" years... "batahan" ? [Indonesian]

[03:09] Audrey: Is it because it's gonna last a long time?

Ayu: A long time.

[03:14] Audrey: 30 years?

Ayu: 50 years maybe.

[03:23] Audrey: And wood, why would you say they use wood?

Ayu: Because wood is... normally in Bali many people like the material from wood because like you know in Bali build normally from wood.

[03:50] Audrey: Now if you want to build a new construction in your home, for example an extension to your home but with no restriction of budget, what material would you use?

Ayu: Wood and concrete.

[04:20] Audrey: Why would you use those? Why concrete and wood?

Ayu: Because the concrete until 50 years like batahan.

[04:38] Audrey: Ok, not going to move?

Ayu: Yes.

[04:41] Audrey: Now if I ask you about bamboo construction, what comes in mind first? What is the very first thing that you think about?

Ayu: Ok bamboo construction: good, like back to nature, cheap and you know like... earthquake?

[05:10] Audrey: Ok like earthquake resistant or not?

Ayu: Yes earthquake resistant.

[05:19] Audrey: What do you think is the cheapest between concrete, bricks and bamboo construction? What is the cheapest? Do you think bamboo is cheaper than concrete and brick?

Ayu: Yes.

[05:38] Audrey: And wood?

Ayu: Yes cheaper.

[05:39] Audrey: Are you sure?

Ayu: Really sure.

[05:42] Audrey: How long does a bamboo house last? How long is it going to stay?

Ayu: Maybe 20 years.

[05:59] Audrey: Can you think of anything that would keep people to use bamboo? Can you think of any barrier to the use of bamboo? Something stopping people from using bamboo?

Ayu: What?

[06:28] Audrey: Why people don't want to use bamboo?

Ayu: Because not so long lasting.

[06:40] Audrey: Can you think of something that can encourage people to use bamboo? Something that would push people to use bamboo? Making them want to use bamboo?

Ayu: Yes I want to help people to say: ok it's better for the future use bamboo. Ok you plant now and in a few years cut and you can make a bamboo.... like... You can also use for like alangs (alangs?)

[07:41] Audrey: For the walls?

Ayu: Yes.

[07:44] Audrey: Now I'm going to show you some pictures. I want you to choose 3 pictures and comment them. You can say what you like or dislike. You can say you don't like some things.

Ayu: Three...

[08:07] Audrey: 3 photos.

Ayu: I like 3 photos and I don't like 3 photos?

[08:17] Audrey: You can choose 3 and either say what you like or don't like.

Ayu: Ok.

[looks at the pictures, picks one]

I like it.

[continues]

I don't like.

[08:41] Audrey: Ok. This one you like, this one you don't like. Can you choose a third one?

Ayu: Hum... I like this.

[08:54] Audrey: Ok. We'll keep the 3. Now could you tell me what you don't like and what you like about these?

Could you tell me what you like?

Ayu: I like this because this is a good... good building, full of bamboo like hum... it's so nature.

[09:42] Audrey: What do you like about the bamboo in this picture?

Ayu: What do I like? Maybe give me an example?

[09:53] Audrey: How about the colours? Is it the colours that you like? Or maybe something else? The light?

Ayu: Okay. I like this design of the room. (writes the word in Bahasa on transator)

[10:37] Audrey: The shapes, you like the shapes?

Ayu: Yes.

[10:40] Audrey: Do you like it's colours?

Ayu: Yes very much.

[10:43] Audrey: And what do you think of the light?

Ayu: Yes. Good because a lot of light.

[10:51] Audrey: Would you like this for your home?

Ayu: I think so, yes.

[10:58] Audrey: For what part of your home would you like something similar to this?

Ayu: Maybe for my bedroom.

[11:12] Audrey: Ok good. And how about this picture? You said you don't like it.

Ayu: Yes.

[11:17] Audrey: Can you tell me why you don't like it?

Ayu: Because no... not the light. It's not very good for indoor because...

[11:30] Audrey: Because it's very closed? So not much light inside.

Ayu: Yes.

[11:39] Audrey: Ok. This one you don't like. Is there something else about this one?

Ayu: No. only that.

[11:43] Audrey: Ok. Now you said you like this one.

Ayu: Yes.

[11:46] Audrey: What do you like?

Ayu: I like the shape and like it's outdoors, like terbuka [indo. for open] Like back to nature, I like this.

[12:10] Audrey: Would you like this in your home?

Ayu: Yes.

[12:14] Audrey: Ok. For what part of your home would you like it best?

Ayu: For kitchen.

[12:20] Audrey: For your kitchen?

Ayu: Yes.

[12:24] Audrey: Terima kasih Ayu.

Ayu: Sama sama.

[12:31] Audrey: Could you remind us why you said you would use bamboo or wouldn't bamboo for your house? You remember when I ask to build a new extension for your home, you said you'd use concrete and wood. Why didn't you think about bamboo?

Ayu: Because it doesn't last long enough.

[13:10] Audrey: You work at Asali Bali, they say bamboo can last very long.

Ayu: Only until 20 years

[13:22] Audrey: Thierry told me it could last way longer. If bamboo lasts 50 years, would you use it?

Ayu: Yes of course.

[13:44] Audrey: If your neighbours built in bamboo, what would you say?

Ayu: It's good.

[13:57] Audrey: You like everything about bamboo but you think it doesn't last long?

Ayu: Yes.

[14:02] Audrey: Ok. Is there something that you prefer in concrete?

Ayu: Hum?

[14:06] Audrey: Do you think it's prettier?

Ayu: Pretty?

[checks it out on google translate]

Ayu: More concrete than bamboo?

[14:50] Audrey: Do you like more concrete than bamboo?

Ayu: Yes.

[14:55] Audrey: Because it lasts long?

Ayu: Yes.

[14:58] Audrey: But it there something else?

[google translate for the words beautiful, pretty, nice]

Ayu: Yeah. For me, cukup.

[15:50] Audrey: Do you think bamboo is more pretty or concrete or brick?

Ayu: What is pretty?

[15:55] Audrey: Cukup

Ayu: Bamboo cukup

[16:03] Audrey: But if you have to rank these. If you have to put one first one second one third. [takes the images of the materials] Which one is the more beautiful?

Ayu: Brick.

[16:31] Audrey: Second?

Ayu: Bamboo.

[16:40] Audrey: So concrete third. But you still want concrete for your house?

Ayu: Yes but for me is more important that it lasts long. Bamboo is this beautiful building and shapes. But concrete is most longer.

[17:14] Audrey: Ok so we are done for now. Thank you. You can have a drink and order a the food you like. We can wait a little.

J. TRANSCRIPT 7 – COMMENTED WALK OF AYU

[00:03] Audrey: So I'm recording you during the visit. You will be filmed. So we are going to visit and you will be filmed. I'm going to let you visit and you can walk wherever you want to go. I'm not telling you where to go, like you go there you go there... You can just feel free to touch the material in the houses. You can tell me

how you feel, what you like, what you don't like. Of you like something you tell me, if you don't like something you tell me.

In your own house, what would you like to change, to add or to build? New bedroom, new kitchen?

Ayu: Okay I want to change my bedroom and with bamboo material...

[01:26] Audrey: So this is your new bedroom. Let's go in your new bedroom. Imagine this is not there there's a sofa and then we go in, and maybe here's your bed, your office, your cupboard for your clothes. This is your bedroom. What do you like?

Ayu: Okay I like my bedroom. And I like my cupboard, and I like my office...

[02:11] Audrey: Now the place. How do you feel about the construction?

Ayu: I like this construction because it is so natural.

[02:24] Audrey: You can touch!

Ayu: Okay it's uh... I like it. Because this is a natural material and so...

[02:44] Audrey: Sustainable?

Ayu: Yes sustainable, and...

[05:50] Audrey: Do you think it's noisy? [claps on the ground and walls to make some sounds, no echo]

Ayu: No, not too noisy.

[03:04] Audrey: Take a big breath, for the smell. How do you feel?

Ayu: [take a breath] yes it's good, the smell...

[03:15] Audrey: The light?

Ayu: The light, light is good for a bedroom, not too ...

[03:23] Audrey: The air?

Ayu: The air... Good.

[03:30] Audrey: What don't you like?

Ayu: Okay I don't like an office, because the office in the bedroom...

[03:43] Audrey: Ok so ne office there. What else don't you like?

Ayu: I don't like this door.

[03:55] Audrey: Ok, why?

Ayu: Because the door is not so... I want to make like... not mirror, but like this, glass, for light. I need more light maybe. This is enough but more is better.

[04:30] Audrey: Do you like the texture, touching it? Or not? Do you like the touch?

Ayu: Yes I like.

[04:39] Audrey: What would you say to describe it? You can say it in Bahasa

Ayu: What is describe?

[04:50] Audrey: [looks it up on google translate]

Ayu: Ok. For this material, bamboo... [talks in Indonesian]... like back to nature, cheaper and safe because earthquake resistant and good for life.

[05:57] Audrey: Do you feel nice?

Ayu: Yes I promise!

[06:01] Audrey: Now we'll go to the other one. Follow me. Mosquito terrible! So now what happens is that your house, imagine there was an earthquake and your house is destroyed. You don't have a house. But I got you a new house. So now we are going to visit, you can visit your new house and tell me what you like, what you don't like and everything, the smell, the lights, the touch... everything. We're just going to take off the shoes before we visit. Here, let's take off our shoes. Go ahead. Here.

[07:26] Owner of the house: Halo, selamat siang, apa kabar?

[07:34] Audrey: What do you think? What do you like? What don't you like?

Ayu: Okay, I like it! Woooow... I like the interior.

[07:51] Audrey: Is it the colours? Or the shapes, maybe?

Ayu: Yeah... Good!

[08:05] Owner of the house: You can hate it, it's okay!

[08:06] Audrey: I always ask what don't you like?

Ayu: Oh I don't know!

[08:10] Owner of the house: If you don't like it it's okay. I don't mind.

Ayu: [Indonesian] ... Bagus! [FTW: bagus means Nice]

[08:17] Owner's wife: Most people don't like it.

[conversation in Indonesian]

Ayu: I like it!

[08:34] Audrey: If you want to go upstairs, you can.

Ayu: [going upstairs]

[Stairs cracking]

[08:48] Audrey: How do you feel about the stairs?

Ayu: What is this?

[08:57] Audrey: Storage

Ayu: Why is storage here?

[09:01] Audrey: Because we don't use it often.

Ayu: I don't like it because maybe I want storage maybe downstairs.

[09:15] Audrey: Ok. Now do you think it's noisy? Or do you think it's...?

Ayu: Well I like it but I don't like it's because the light.

[09:25] Audrey: Not enough light?

Ayu: Yeah.

[09:28] Audrey: How do you feel about ... [touches the walls and handrail] is that good for you?

Ayu: Yes this is good for me!

[09:38] Audrey: Do you think it's strong? Weak? ... Do you think it's strong?

Ayu: Yes strong. Yes, very strong.

[09:48] Audrey: Do you feel safe? Do you feel comfy? Do you feel hot? Maybe too hot?

Ayu: Too hot, yes. For me this is too hot.

[10:05] Audrey: Would you change your house for this one?

Ayu: Yes!

[10:12] Audrey: Are you sure?

Ayu: Really.

[10:14] Audrey: Are you really sure? Because you can say no you know? I like it when people disagree. You can disagree?

Ayu: Yes! But I like it. I want to change... Only my bedroom not my house.

[10:34] Audrey: Ok that's good to know, we'll come back to this. [going downstairs to the bedroom] You want to have a look? Would you like a bedroom like this one?

Ayu: [whispering] Yes! I like it.

[11:02] Audrey: I'll let you just process it and then I'll come back with a few questions about this. Okay? I will let you time to rest and then a few more questions. Have a last peak if you like.

[11:25] Owner's wife: If you want to see the kitchen, come have a look.

Ayu: [goes in the kitchen]

[11:37] Audrey: Look at the walls, ceilings...

Ayu: [speaks Indonesian= I think bamboo is describing nature. Use bamboo is cheaper, back to nature and I feel nice also good for life.] Bagus!

[11:47] Audrey: Bagus, nice! If you have anything to add? I'll let you go back to the group. I'll take the camera back as we're done with today's visits. Terima kasih Ayu!

K. TRANSCRIPT 8 – INTERVIEW POST COMMENTED WALK OF AYU

[00:03] Audrey: How did you feel during the visit ?

Ayu: I feel happy

[00:13] Audrey: Why?

Ayu: Because back to nature, I see new building house. New experience for me.

[00:31] Audrey: Would you build in bamboo now? You previously said yes but not for all my home. Just for your bedroom. Why is that?

Ayu: Because only me like bamboo.

[00:50] Audrey: What about your family?

Ayu: I don't know. Because my family never come to a place like this place and never see a bamboo house. Maybe if they come to this place and see the bamboo house, maybe yes.

[01:14] Audrey: Ok, maybe they'd like that but for now they don't?

Ayu: No.

[01:20] Audrey: Why do you think they don't like bamboo?

Ayu: Because not long lasting.

[01:34] Audrey: If one of your neighbours built in bamboo, what would you tell them?

Ayu: I'd want to tell them "Oh this is bamboo! It's really good for you. A good resistance. Cheaper than concrete and steel or what."

[01:58] Audrey: How long do you think a bamboo construction lasts? How long in time does the bamboo house last, does a bamboo house can stay?

Ayu: How long?

[02:10] Audrey: How long in time, how many years will the house be there?

Ayu: Like 20 years

[02:23] Audrey: Ok 20 years. Did you change your mind about bamboo during the visit?

Ayu: Yes.

[02:30] Audrey: Ok.

Ayu: I changed my mind.

[02:33] Audrey: During this visit?

Ayu: Yes

[02:34] Audrey: Ok. Why did you change your mind? What made you change your mind?

Ayu: Because it's bamboo, it's so beautiful, it's natural.

[02:47] Audrey: That wasn't the first time you saw bamboo though?

Ayu: Yes but because I only saw simple simple building but now I see a beautiful building.

[03:03] Audrey: This is a home. Is this the first time you see a bamboo house like this one?

Ayu: Yes this is first time.

[03:11] Audrey: But you have seen a lot of building in bamboo already with Olivier and Antoine at work?

Ayu: Only seen, not like now. Only like also more than now. Ok Only seen like this, like this, like this, like this, fast nananah. Not so: "okay what do you feel about this?" not like that. Only: "ok we are building a building like this and nananah" Ok. Not so "ok, what you feel about this building? If you had this building how would you feel?" and that made me change my mind.

[04:02] Audrey: Can you think about something that would stop people from constructing in bamboo? Why wouldn't people want to build in bamboo?

Ayu: Not long lasting and maintenance is too expensive because hum ok for 5 years you have to treatment because of you not treatment you'll have cracks and termites.

[04:45] Audrey: How much do you think it costs, a bamboo house? Price?

Ayu: 2 million rupiahs and half, 2 million rupiahs until 2.5 million rupiahs per meter square.

[05:08] Audrey: To sum up, is there anything you want to add? Is there something more you want to say?

Ayu: No.

[05:15] Audrey: No you're good?

Ayu: Yes. (giggles)

[05:19] Audrey: Ok. Terima kasih Ayu.

L. TRANSCRIPT 9 – IN-DEPTH INTERVIEW OF ADE PARMITHA, STUDENT

[00:04] Audrey: Ok, so now I am recording you. Could you repeat your name and where do you live?

Ade: Yes my name is Ade Parmitha. I live at Denpasar.

[00:15] Audrey: How old are you?

Ade: I'm 21 years old.

[00:20] Audrey: Are you still a student?

Ade: Yes, I am a student.

[00:22] Audrey: What do you study?

Ade: I study at the University of Mahasaraswati Denpasar, major at the English literature.

[00:30] Audrey: Now, could you tell me about your home, your house? I know you brought pictures.

Ade: Yes.

[00:36] Audrey: Can I see them?

Ade: Alright here they are.

[00:53] Audrey: Okay good, terima kasih.

Ade: Sama sama.

[00:58] Audrey: So this is your home.

Ade: Yes.

[01:01] Audrey: Where is this?

Ade: This is what I call Bale Danga. it's in the north of the house. It is made of bata and a little bit of concrete.

[01:22] Audrey: Concrete and tiles, and a little bit of bricks? is this bricks? Just in front of the concrete?

Ade: Yes just in front of the concrete. Now this is wooden, for the doors. Now this is my nephew's house, like in front of my house. Here's my room.

[01:48] Audrey: Your bedroom?

Ade: Yes my bedroom, from concrete also and wooden. Now this is the front of my living room, the best feeling is from bamboo, so this is good.

[02:10] Audrey: So this is wood, and then this is bamboo woven?

Ade: Yes. this is Bale Danga, and this is like my Terrace, my room terrace. and this is very close to the living room.

[02:29] Audrey: So is the living room inside?

Ade: Yes.

[02:32] Audrey: Do you spend a lot of time on the porch?

Ade: Yes, like on the Terrace and in the Bale Daging with my family. This is the Sanggah Kemulan. it is the temple in the house of Balinese people. in the second floor of my house. this is 1 and then this went in front of my house.

[02:56] Audrey: So what is there upstairs? what do you do?

Ade: Prayers. Like prayers yes.

[03:08] Audrey: Ok good, thanks. And how many people live with you there?

Ade: Five. Me, my father, my mother and two of my sisters.

[03:23] Audrey: Ok, nice, very good. You already told us what your house is made of. Now what would you say is the good sides, like the pros and cons of the materials in your house? What do you think is good with those materials?

Ade: What is good is that it is simple, and et cetera. It is cheaper, like not expensive save to spend money. Not like the bata [FTR. bata = bricks], the wooden.

The not good is that it is mouldy in my house. Mouldy if it's like the rainy season, the ceiling is not good for this rainy and like leaking and it becomes like mouldy also too. But the good is like the long term.

[04:30] Audrey: It takes up the water and it becomes mouldy inside the house? So that is not good?

Ade: No not good. like that mouldy and all.

[04:47] Audrey: So if in your home if she were to build a new construction maybe a completely new home, or maybe a new part for the home, what would it be? the new bedroom? a new living room?

Ade: I'm afraid it would get mouldy again but I would choose concrete also.

[05:13] Audrey: Ok, so you would choose concrete?

Ade: And maybe wooden. but the good one, Jati [FTR. Jati = Teak]. I don't know how the bamboo is, if it's good or not. Because in Denpasar, in my location it is mouldy and wet. Things in my house, I don't know what, if wooden in my house is good or not. But it's mouldy.

[05:52] Audrey: So he would rather have concrete. But what would it be for? What do you think a new part of your home would be? Would you like a new bedroom or a new kitchen?

Ade: Yeah, a new kitchen and a new living room. because you know in the rainy season it is always leaking. so I don't know why my father keeps the ceiling with the

bamboo because usually the leaking is always disturbing us and I can't... because in the other picture inside my bedroom it is already concrete.

[06:36] Audrey: So now I am going to talk to you about bamboo construction, we are now really going to talk about bamboo. Now what is the first thing that you think about when you hear and you think of bamboo construction?

Ade: Maybe comfortable but past, the bamboo... local products for Balinese old people, maybe comfortable and comfy.

[07:05] Audrey: Would you build in bamboo? Maybe in other conditions, maybe not in your house, but somewhere else if you moved out? Would you build in bamboo?

Ade: Yes of course because it is like in my family and maybe bamboo is cheaper than concrete. I don't know about the long terms. But maybe for villager people it's good, like here it is good for bamboo but I don't know for Denpasar because it's all the millennials, not too much possible with the bamboo and the wooden.

[07:50] Audrey: And if in Denpasar you chose to build a bamboo House what do you think your neighbours would say?

Ade: Maybe unique and they would maybe ask me: is it good for the long terms? Because in my town in Denpasar, it is hot and I don't know if the bamboo is good for the build in Denpasar. Because it's very hot and if we have the bamboo we also have the air conditioner inside the room.

[08:28] Audrey: Do you have air-con at home?

Ade: No. because the electricity is very expensive. we just have the fans.

[08:46] Audrey: What would you say is the cheapest between concrete brick and bamboo? I think I have picture but we can do without. Could you rank bamboo construction for structure, concrete or brick? What would you say is the most expensive and what would you say is the cheapest?

Ade: What is Brick?

[09:36] Audrey: Brick is this. [Audrey finds the picture of the brick wall]

Ade: Oh ok.

[09:46] Audrey: This is concrete, this is brick, this is bamboo. Could you put cheapest here and most expensive here?

Ade: Hu this is cheapest. And then this one in the middle. and then...

[10:00] Audrey: ...and then concrete more expensive ok. Ok so I repeat for the record: so bamboo cheapest, then brick and most expensive is concrete. Now, how long would you say a bamboo construction would last, in your opinion?

Ade: Maybe 2 years.

[10:25] Audrey: Ok, 2 years?

Ade: I don't know! [both jiggle]

[10:31] Audrey: Okay, that's not long. But it's in your point of view, so that's just what I asked. No problem! Can you think of some barriers that would stop people from building with bamboo?

Ade: No because maybe it is good for construction the bamboo from like restaurants or for the furniture maybe, like wooden thing for example from bamboo a chair is ok. So for furniture. But I don't know for the construction because if we build by bamboo, I don't know the long terms.

[11:15] Audrey: Ok. Now I'm going to show you some pictures, you can choose three and you can tell me why. You can choose if because you like it or because you don't like it. So you choose three pictures and you comment them I like this because of that, I don't like this because and tell me why.

Ade: [looks at the pictures]

[11:58] Audrey: Do you want to choose that one?

Ade: Yes. It is good because it has two floors and I love this... How do you say?

[12:12] Audrey: Alang-Alang.

Ade: Yes, the alang-alang for...

[12:016] Audrey: For the roof?

Ade: Yes for the roof.

[12:32] Audrey: Is there something else you like?

Ade: The interior, and like maybe from the outside. The inside is very good, it's comfy maybe for a house. but maybe in the village it is good but not in the city.

[12:53] Audrey: So you like it? Would you like to live in it?

Ade: Yes of course.

[12:58] Audrey: But maybe not in Denpasar? Maybe more in the village...

Ade: No! Maybe I would in my hometown in Gianyar. This is good! In front of the household.

[13:11] Audrey: So this is good. Now can you choose another picture?

Ade: This is also good.

[13:22] Audrey: Ok.

Ade: To meet with my family maybe for the relaxing. So you put it maybe near, in front of the house.

[13:44] Audrey: Do you think bamboo there is a good solution?

Ade: Yeah because I have seen this like Bali bamboo in my hometown. This is a very Common thing. In the afternoon if you want to take a nap, over there it is very nice.

[14:02] Audrey: Better in bamboo or concrete or wood?

Ade: Bamboo is better for this, for the relaxation, for spending some time over there.

[14:16] Audrey: So what is it that you like? Do you like the colour, or is it the sh...?

Ade: I like the shape. And this is maybe it is strong enough for maybe 4 or 5 people. So this one.

[14:41] Audrey: Now if you want to choose one that you don't like, you can also...

Ade: Maybe this one, I don't like it. What is it? Is it a house?

[14:53] Audrey: Yes, it is a house.

Ade: I don't like it because of the roof, and this is not too... maybe... maybe the air will come to inside.

[15:15] Audrey: I think the house is not finished, it still has to have a roof, and then here we have to put a proper window. But it is more like the space. Do you think it could be nice or could be bad?

Ade: Maybe it could be bad, I don't know. It's too... I don't like... I don't know how to say it. It's too much wooden, the interior I don't know, but from outside I like this one better than this one.

[16:12] Audrey: Is there another picture you want to talk about?

Ade: Maybe just this one, with the living room. It is good because I like the sofa the table. It's just that in my hometown many years ago when we changed the sofa from the latex for another one, my grandfather bought this bamboo for the sofa and it was very comfy.

[16:49] Audrey: And what about the rest of the space, do you like the colours?

Ade: The colours are very natural, it's very good also the interior. The stairs also. I think it's also very good, it is very tidy.

[17:20] Audrey: If there is one what more you want to talk about you can.

Ade: No it's enough.

[17:27] Audrey: Ok now can you remind me, for you, the pros and cons of bamboo construction? The advantages and the disadvantages, can you remind me?

Ade: For the bamboo the cons is... maybe environment friendly and cheaper, and supports the local craftsmanship from Bali. False is the long-term maybe. I don't know how many years the bamboo is good for the house. But maybe the bamboo is good when they build until they are finished to minimize the broke.

[18:32] Audrey: Well thank you, this is over. Thank you for answering and we will soon go to visit.

M. TRANSCRIPT 10 – COMMENTED WALK OF ADE

[00:07] Audrey: So I'm going to let you walk around and you'll be the one deciding where you go. I won't be guiding you this is a free visit. This one is really short and then there will be another one there. I asked you to just walk around and tell me are you feeling what you think about the space. The cameras are already there, I'm recording you. So when we were talking earlier, I was asking you what you want for your house, a new kitchen maybe or a new bedroom... So just imagine you're building an extension to your home and the work is done the construction is there. And we're going to go you're going to discover what do you want it to be ? A new kitchen?

Ade: Yes!

[01:07] Audrey: Ok so this is your new kitchen. Imagine that there is a sink, and everything you need even though right now it is not a kitchen but you can imagine it being a kitchen. So here the work is done here is your new kitchen. You can just visit it and comment.

Ade: Oh this is good is there a lamp?

[01:34] Audrey: I don't think so. Imagine there's a lamp, there's definitely a lamp in your kitchen!

Ade: This is good.

[01:46] Audrey: Where do you want to put your stove and fridge?

Ade: I want to put my stuff near this window. It is good for the air. Maybe they think like they're like this and the place with the plates right there and maybe some table for cutting the vegetable could go over there would it be ok to put some storage.

[02:17] Audrey: Yes, of course storage!

Ade: You know because Balinese have a lot of stuff maybe plates and things to put in the storage.

[02:33] Audrey: Ok so now what do you think of the place, of the construction?

Ade: It is good it is not really small I think it is enough for me to...

[02:50] Audrey: To have your kitchen?

Ade: Yes my kitchen.

[02:54] Audrey: And now what do you think about the materials?

Ade: It is good, this is not concrete?

[03:04] Audrey: No.

Ade: Only wood and bamboo?

[03:07] Audrey: No, so this is bamboo, and this is mud, you know like earth you put it and then you let it dry.

Ade: Oh I thought this was wooden. It is good, it is nice.

[03:24] Audrey: And what do you think of the atmosphere? Do you feel good?

Ade: Good because the window is on every wall, and the upstairs is good... I mean the roof. You know for the air circulation, it is good.

[03:49] Audrey: And what do you think of maybe the smell or do you think there is a smell?

Ade: No!

[03:56] Audrey: Ok so what do you think of the feeling if you touch it? Do you like it?

Ade: I don't know this is like a little dusty but it's still nice.

[04:07] Audrey: And the bamboo? How do you feel with it?

Ade: This is strong enough. This is only bamboo or is it has the iron inside?

[04:17] Audrey: No this is just bamboo.

Ade: Oh just bamboo! It's good! [knocks on the columns] So this is strong enough for me. Yes, it is good overall I really like it. It is the first time I saw this.

[04:42] Audrey: Now, we are going to go to the other place. I always take off my shoes for the other place we can take off our shoes so this is the owner's house and so now the scenario is that OK they have been a catastrophe, and you lost your home but you have a new home. Ok? You don't really know what it's made of, you don't know how it is but we are going to visit it and you are going to tell me how you feel about it. So that was your kitchen, but then it got destroyed and now you've got a new home you can go. Ok, there are some people in your home but that's ok. So, it is the same, I'm going to let you just visit the way you want. And you can just comment like the same way you did for the first building.

Ade: [goes in and stops] Wow. Good.

[06:06] Audrey: Do you like it?

Ade: Is this a sofa?

[06:09] Audrey: Yes, this is like the living room, where's the kitchen.

Ade: Waw, this is surprising. It's good. and it smells like... nice.

Owner's wife: It smells like vinegar.

Ade: Yes vinegar. It's looking good.

[06:41] Audrey: Now if you want to touch the bamboo go ahead. Do you want to go up?

Ade: Is this strong enough for me?

[06:52] Audrey: Just go up and find out!

[stairs cracking]

Ade: I'm a little scared. So this is all of bamboo, no iron maybe inside?

[07:13] Audrey: Yes, no!

Ade: Well it is good. How long this house has made?

[07:25] Audrey: This is your house. Imagine, it is not new you'll found out afterwards. For now just imagine this is your house. Do you like it how do you feel?

Ade: I feel like I am in my hometown it is really good, natural and unique, it is very comfy. Is this a bedroom?

[07:52] Audrey: Yes is the friends' bedroom, there is another bedroom down there. So there is two bedrooms.

Ade: This is good too.

[08:05] Audrey: How do you feel about the sounds maybe?

Ade: The sounds?

[08:11] Audrey: I mean is it not too noisy?

Ade: No, this is good. And I feel comfy in this building, because of all of this bamboo. Now about maybe concrete and the expensive... This is nice!

[08:38] Audrey: So do you feel like it's cheap?

Ade: But still luxury I think.

[08:43] Audrey: Ok, good, it is nice.

Ade: I mean it is good.

[08:47] Audrey: Do you like the touch of it because I noticed you're touching it a lot.

Ade: Yeah because it is the first time I saw the bamboo very big like that and I think inside the bamboo it is iron then...

[09:02] Audrey: You do this [knocking on the bamboo].

Ade: Yes, this is bamboo, really bamboo! Wow, it is good. And like this one, it is like the ceiling in my house, like we talked before... It's alang alang.

[09:16] Audrey: So here, you can see it on the roof and it doesn't leak.

Ade: And it doesn't leak? It's good. And outside it is hot weather but now it's not too hot, it is really good. Maybe in the rain season, it's less good smell, maybe, from the roof and from the bamboo.

[09:57] Audrey: There's the other bedroom, we might not want to go there for intimacy.

Owner: you can go see the bedroom, you're not going to sleep upstairs.

[10:15] Audrey: So here's her new bedroom and your bathroom.

Ade: Oh wow outdoor bathroom, this is my favourite. I imagined that I have that in my house in Denpasar, it's not ok in Denpasar because outside is very hot, and there's a lot of people around me and they could see me. But in my hometown it's ok. It's good. The atmosphere from outside is good. Is this stone?

[11:02] Audrey: Yes. Now, I'll let you take a last walk around, an interview do one last time later, I will let you process it and then I'll come back for some more questions. Let me know if you have any question, ...

[Audrey talking to the owner] She was just asking before how long ago the house was built?

Owner : 10 years ago.

Ade: 10 years [loudly, looking surprised]? Wow. can't imagine it! The bamboo is this some kind of specific bamboo?

Owner: It's treated with borax acid.

[Ade and the owner having a discussion in Indonesian:

Owner : All of this bamboo was treatment before we use for house. Since they not affected by sun shine, and the roof replaced at least 5 years once, they will good enough.

Ade : Are this bamboo getting mouldy?

Owner : No , aren't. But when rainy, mouldy is impact for our clothes. They become mouldy and have bed smell.

Ade : I was think, that house with bamboo only survive at 2 years. But in real life, they can be longer than in my opinion before.

Owner : Yes, the challenges is only at roof, because they are from "Alang-alang" and must be clean from dust.]

[12:41] Audrey: She was worried in the interview before, she told me got bamboo could only last 5 years, is that what you said?

Ade: 2 years! I think that before because rayap [indo. for termites]. Just termites because if it's not treated.

Owner: Yes, you can get beetles. [talking in Indonesian again]

Ade: Yes, this is good it's very surprising that it's 10 years, wow!

[13:33] Audrey: And it might be longer, it's in good shape. I mean, really good shape. Maybe a lifetime.

Owner: I hope longer.

Owner's wife: yes, it must!

[13:45] Audrey: Thank you have the next visit and then I'll ask you some more questions, there you go. Terima kasih banyak.

Ade: Sama sama. I will tell my father later about this!

N. TRANSCRIPT 11 – INTERVIEW POST COMMENTED WALK OF ADE

[00:01] Audrey: Aren't you too tired?

Ade: No, I'm very excited because it's the first time I visit a place like this. Because most of the bamboo, for example in Bali, very expensive to visit. Very expensive.

[00:21] Audrey: How did you feel during the visit?

Ade: Very excited, wonderful and comfy.

[00:32] Audrey: Would you build in bamboo?

Ade: Yes, I think in my hometown I will build if I know treatment like said Owner's husband.

[00:44] Audrey: You mean Owner?

Ade: Yes, like Owner said, if you have a good treatment in bamboo and replace it 5 years' time, 5 years, you can build in bamboo, you can get the long terms.

[01:07] Audrey: Actually you treat it and then you can keep the same a long time, just have it treated every 5 years. And you can keep it a very long time. The treatment is like you soak the bamboo in really big baths and you leave it there in the chemicals, and then you dry it and you can just leave it like that. Just have to replace the alang-alang.

So why would you build in bamboo?

Ade: Because it's environment friendly, cheaper one. Because you know the concrete is very expensive and it's cheaper, bamboo is good.

[01:55] Audrey: How long do you think it can last now?

Ade: More than 10 years. Maybe same like my house 20, maybe even more than 20.

[02:10] Audrey: So what changed your mind?

Ade: Because I know I can support the local bamboo, and I have to maybe promote and have the bamboo in Bali. And I can build the bamboo, a house with the bamboo and good treatments and you can build a good one and make it comfy.

[02:45] Audrey: Is there something that would stop you from building in bamboo? Like is there a condition?

Ade: Well maybe if it's in the rainy season if the mouldy or the termites, this would stop me. But once again, if I have the good treatment, yeah, bamboo is a good solution for me right now.

[03:12] Audrey: What in your opinion is the range of cost of bamboo construction? So for a bamboo house, how much do you think it would cost?

Ade: The nominal or maybe just for...?

[03:26] Audrey: For an average house like this one?

Ade: Not too expensive, like maybe you can spend, cheaper, more cheaper than if you use the furniture like wooden. Or like less, maybe yeah cheaper than those.

[03:45] Audrey: Could you say a price?

Ade: Maybe 15 million, you can have a bamboo house and the with a good furniture.

[03:59] Audrey: How big the house?

Ade: Just like Owner's house.

[04:04] Audrey: Ok, like Owner's house. So to sum up is there something that you want to say, something you want to add?

Ade: For bamboo maybe in my house, maybe I can combine with the wooden because I think mix-and-match bamboo and wooden is also good. And for the interior, maybe I can put some just like still like stone, like what's best in Owner's, like the bathtub in stone. Yeah it's good to mix and match with the local brands and architecture.

[04:58] Audrey: Thank you very much Ade, you can send me Devi. Suksuma!

Ade: Mowali.

O. TRANSCRIPT 12 – IN-DEPTH INTERVIEW OF DEVI MARIANI, EMPLOYEE

[00:01] Audrey: Ready?

Devi : Yes.

[00:03] Audrey: Ok now it is recording. Can I ask you to remind us your name?

Devi : My name is Devi Mariani.

[00:08] Audrey: And where do you live?

Devi : I live in Denpasar.

[00:13] Audrey: And how old are you?

Devi : I am 22 years old.

[00:17] Audrey: Ok. What is your main occupation, what do you do?

Devi : Now?

[00:24] Audrey: Are you still a student?

Devi : No I am working.

[00:28] Audrey: Where do you work?

Devi : In hospitality.

[00:37] Audrey: Could you tell me about your home?

Devi : I can tell but I not speak English so well.

[00:45] Audrey: Ok just try and if you don't really know you can say it in Bahasa Indonesia and I will ask her friend afterwards to translate.

Devi : My home is... Tell like what?

[01:02] Audrey: Many people live in your home?

Devi : In my house we are 4 people: my father, my mum, and my brother and me.

[01:12] Audrey: How many constructions or rooms do you have?

Devi : I have a four rooms in the house and then one kitchen and one bedroom.

[01:25] Audrey: So 4 rooms plus kitchen and then bathroom?

Devi : Yes one bathroom one and also the living room one.

[01:35] Audrey: Now could you tell me are they all constructed together or is there more one room and then further another one... ?

Devi : In the living room: 1, 2, 3, 4.

[01:54] Audrey: And you have to go outside to go from one to another?

Devi : No, in the inside all. And then the kitchen inside, and then the bathroom one beside the kitchen.

[02:05] Audrey: What are the material that are used? Wood? Timber? Or maybe concrete? Or brick? [Audrey takes out images of the materials] Do you have this? Or this?

Devi : I have this.

[02:31] Audrey: Ok so concrete. Is your house made of this?

Devi : Yes.

[02:36] Audrey: Not bamboo or brick.

Devi : No.

[02:41] Audrey: Not wood neither?

Devi : What is wood?

[02:44] Audrey: [Audrey shows her a wooden column in the restaurant]

Devi : Oh. No.

[02:54] Audrey: What about your neighbours? Most people in Bali, do you think of the build in this or this?

Devi : This one.

[03:03] Audrey: Ok so most people build in concrete.

Devi : Sometimes maybe this and this.

[03:10] Audrey: Ok to sometimes bricks sometimes bamboo but mostly concrete.

Devi : Yes.

[03:19] Audrey: Why do you think people use this? Why is it good?

Devi : Because the concrete is the maybe... Murah. [indo. For cheap] down price maybe.

[03:40] Audrey: Cheaper?

Devi : Yes cheaper.

[03:46] Audrey: Ok so concrete it is cheap. No if you had to build a new home for you, maybe all the house or maybe just a kitchen, as you want, and you have as much money as you want so no money problem, which material would you choose?

Devi : I think like trees.

[04:14] Audrey: You mean wood? Timber?

Devi : Cayu jati [indo. For teak].

[04:20] Audrey: Ok good. Now if I tell you about bamboo construction, what is the first thing that you think about?

Devi : Bamboo sometimes we use it for the lying... In bahasa it is layan-layan [indo. For kite].

[04:44] Audrey: Ok I think I see what you mean. They use bamboo for that?

Devi : Yes. And then for the water?

[04:56] Audrey: You mean canalizations?

Devi : Yes. And for like this. [showing the ceiling framework]

[05:05] Audrey: For the roof?

Devi : Just for the rooftop. Maybe just... Just...

[05:16] Audrey: It's ok you can say it in Indonesian.

Devi : [speaks Indonesian : That's all I know. And I like because that is good for relaxing and meet with family.]

[05:28] Audrey: Would you, for your house, build something in bamboo?

Devi : No.

[05:35] Audrey: Ok why not?

Devi : Maybe someday I will try.

[05:45] Audrey: You can just say no, if you don't want to build in bamboo...

Devi : I don't know maybe it's interesting.

[06:00] Audrey: Ok if you don't want to build in bamboo, are you scared of something?

Devi : No.

[06:10] Audrey: What do you think if your neighbour build something in bamboo, what think of his house?

Devi : I cannot tell this in English. Maybe can you replay your question?

[06:33] Audrey: Ok if your neighbour or maybe a friend builds a house in bamboo, what are you going to tell them? What would you think.

Devi : I think it's good, yes. Just like that.

[06:48] Audrey: How long do you think it is going to last?

Devi : Going to finish?

[06:54] Audrey: I mean, it's built but how long do you think it's going to last in time?

Devi : I think it is a long time maybe.

[07:03] Audrey: Ok how long?

Devi : 5 years or maybe 10 years.

[07:09] Audrey: Ok so these are images of materials: could you put the cheapest here and here the most expensive?

Devi : Cheapest this, in this expensive.

[07:31] Audrey: Ok so concrete, I will repeat for the record, concrete and brick of the same, the cheapest then bamboo more expensive.

[interaction with the owner of the house we'll visit later]

[08:01] Audrey: So now I am going to show you a couple of pictures, can you choose three?

Devi : I choose one?

[08:14] Audrey: Three.

Devi : Three, alright. [looks at the pictures]

[08:34] Audrey: You can either choose pictures that you like or that you don't like.

Devi : I like three and I don't like three?

[08:43] Audrey: You can just pick 3 and then comment what you like or don't like. You can choose 4 if you want.

Devi : This is so good, what is that?

[09:02] Audrey: That is mud, adobe, construction. Made from earth and then bamboo for the roof. Why did you like it, why did you choose this? What did you like?

Devi : The look., lookness.

[09:19] Audrey: Ok the look, is it the shape?

Devi : Yes.

[09:26] Audrey: Or is it the colour?

Devi : Colour!

[09:32] Audrey: Ok so colour and shape. And what do you think of this?

Devi : It is good. I like the white. Yes. And then this maybe. And the rest is good. Overall it's ok, this I like this.

[10:14] Audrey: What do you like about it? Why is this better than concrete for example? Is it better than concrete?

Devi : In Bahasa it's ok? [speaks Indonesian]

[10:53] Audrey: Ok thanks I will translate later.

Devi : I'm sorry.

[10:56] Audrey: It's ok it's fine, I don't speak Indonesian and you speak English that's good. Can you choose the last one?

Devi : Last one, yes. I think this one.

[11:25] Audrey: Do you like it?

Devi : Yes.

[11:34] Audrey: What do you like about it?

Devi : It is the same, the look, and for the look the view it's good. I mean over there. And then... That. What is the name?

[12:04] Audrey: Alang-alang.

Devi : Alang-alang yes. In Bahasa, is rapi [indo. For neat]. Rapi and simple, it's the look simple.

[12:20] Audrey: Can you remind us quickly the good and bad sides of bamboo to you?

Devi : Of bamboo?

[12:30] Audrey: Just in general, what is the good and bad of bamboo.

Devi : Is the good... Is the bad maybe in bahasa, has rayap [indo. For termites]. Is the...

[12:48] Audrey: Termites or dust?

Devi : Yes dust maybe, pasir [indo. For dust]. And then makes it dirty. And the good of bamboo is the strong.

[13:15] Audrey: Thank you, we're finished.

P. TRANSCRIPT 13 – COMMENTED WALK OF DEVI

[00:01] Audrey: So I am starting to record you. You will be filmed. So now I am going to ask you: what in your home do you want to change or add? Construct new?

Devi: Change? Building?

[00:19] Audrey: Did you want a new bedroom or a new kitchen?

Devi : One more bedroom.

[00:27] Audrey: Ok so now we are going to visit a building and it's your new bedroom. We just built a new bedroom. It is not a bedroom that you can imagine that it is. Imagine that this is your bedroom. Ok?

Devi : Ok.

[00:43] Audrey: So just forget that there is this. This is like a sofa, and then we go into your bedroom. So this is your bedroom.

Devi : Ok.

[00:57] Audrey: This is your bedroom. What do you think?

Devi : May be too small.

[01:03] Audrey: Ok it is a small bedroom. What do you think of the place.

Devi : Good and simple. Simple, I think simple.

[01:22] Audrey: So where would you put your bed?

Devi : I'd put my bed here, like that, yes. And then this is like hum...

[01:34] Audrey: A cupboard? For your clothes?

Devi : No, no, like a table. And then this is the lemari [indo. For cupboard]. For my clothes. I think this is the... Same like air conditioner. Like this.

[02:06] Audrey: No how do you like it. Do you like the touch?

Devi : No it is too hot. And the touch is good but not smooth...

[02:22] Audrey: Ok so not smooth enough?

Devi : Yes, not smooth enough.

[02:28] Audrey: And the look? Is it pretty or not?

Devi : Simple, in Bahasa: sejuk! [Indonesian for "cool"]

[02:44] Audrey: How do you feel?

Devi : Comfort and lonely.

[02:49] Audrey: Lonely?

Devi : Yes lonely but this is great for the me-time.

[02:56] Audrey: Ok for the me-time, nice. Now the smell is ok?

Devi : Yes ok.

[03:04] Audrey: And the sound maybe? Like when you walk? Is it not too noisy?

Devi : No, it's ok.

[03:12] Audrey: And the light maybe?

Devi : The light maybe because I am scared of the dark so if we have a lamp...

[03:25] Audrey: Do you think it needs and learn to during the day?

Devi : No it's for the night.

[03:35] Audrey: Ok so that was your nice bedroom. Now I'm going to take you to another place but what happened is that there was an earthquake, the ground shaking.

Devi : No.

[03:51] Audrey: I'm telling you imagine your house got destroyed, you've got no house.

Devi : Ok.

[04:04] Audrey: You ask people to build you a new house because you had no house. And they were going to visit your new house.

Devi : Yes ok.

[04:12] Audrey: Ok so this is your new house and you're going to discover it. I want you to tell me what you think the new house. If you like it or if you don't like it, maybe the lights, the smell... When you touch it, the texture...

Devi : Ok.

[04:30] Audrey: Feel free to go.

Devi : Thank you.

[04:34] Audrey: Can you just take out the shoes just before we go in the house?

Devi : Yes sure.

[04:58] Audrey: You can come in.

Devi : Hello!

Owner: Selamat bahan, welcome to your home. Make yourself at home. Here's your coach.

Owner's wife: You can test it.

[05:17] Audrey: Yes the bamboo coach sounds comfortable.

Owner: If it wasn't for the cash we would have moved out.

[laughs]

[05:26] Audrey: Ok so let's have a seat. So how do you feel about the house?

Devi : Good, good.

Owner: [laughs] You can say it's bad it's ok.

Owner's wife: you're going to need a lie detector. [laughs]

[05:44] Audrey: Look and say what you feel in Bahasa Indonesia, I'll get someone to translate later.

Devi : Smell is good, it's comfortable.

[05:54] Audrey: Yes, thanks to the coach. It's comfortable.

Devi : Yes, I want to sleep here.

[06:06] Audrey: What about the place do you like the shapes?

Devi : Yes simple shapes and then the lights. Maybe someday when I grow up I can live in a place like that. It's good.

[06:24] Audrey: Is there something you don't like?

Devi : No it's good.

[06:31] Audrey: Do you feel at home or comfy here or...?

Devi : I feel like I want to have a home like this.

[06:42] Audrey: Ok nice. Do you want to go upstairs?

Devi : Yes. And all of that is made with bamboo?

[07:12] Audrey: Yes. This is alang-alang, ...

Devi : Can I see that?

[07:23] Audrey: Yes of course. Ok so you've got a bit of storage. [Devi touches the bamboo] Do you like the texture here?

Devi : Yes it's really smooth. Better than before

[07:42] Audrey: Smooth enough?

Devi : Yes enough. It's all good.

[07:56] Audrey: Is there anything you would like to change, if this is your home?

Devi : Maybe this one, change. Because if it's rains... [shows the open window]

[08:16] Audrey: No this doesn't leak, because you know goes on top of the other one.

Devi : I really like it.

[08:31] Audrey: Do you feel peaceful?

Devi : Yes peace!

[08:42] Audrey: What about the smell?

Devi : The smell is good.

[08:48] Audrey: How about the noise? Do you think it's too noisy? And downstairs? They are talking downstairs how about the sounds up here?

Devi : No really no noise except the "creek creek" like [walks to make the noise] I can't hear them.

[09:16] Audrey: Now let's go see the bedroom downstairs if you want to see it. Go ahead.

Devi : I feel cool.

[09:37] Audrey: Cold?

Devi : No not very cold, it's normal... Fresh!

[09:47] Audrey: And here's the outside bathroom if you want to have a look.

Devi : It's so simple.

[10:10] Audrey: If you don't like something don't hesitate, you can just say you don't like.

Devi : I don't like this maybe in Indonesia lumuk [indo. For moss]. It makes the mosquito come. Overall it's good I like this house.

[10:37] Audrey: Do you like the atmosphere? The way you feel?

Devi : It's good. Feels good.

[10:42] Audrey: Everything's good! Terima kasih.

Owner: Do you want to rent it?

Devi : What?

Owner: [speaks in Indonesian]

[Laughs]

Devi : I don't know is it cheaper?

[jokes in Indonesian, laughs]

[11:10] Audrey: Would you rather live here or in a concrete house in Denpasar?

Devi : I think this, because Denpasar it is very crowded, with traffic, it's hot... Too much.

[11:25] Audrey: Ok. Good.

Devi : Thank you very much.

Q. TRANSCRIPT 14 – INTERVIEW POST COMMENTED WALK OF DEVI

[00:03] Audrey: So how did you feel in the visit?

Devi : How do I feel? It's ok good, but just there were many mosquitoes...

[00:14] Audrey: Would you build in bamboo?

Devi : Yes I will someday.

[00:19] Audrey: Why?

Devi : Because it is like new, but this might be like one year, two years... But then Owner's house is 10 years already! I think it is a long house. It will be a long house if I build with bamboo.

[00:44] Audrey: And if one of your neighbours built with bamboo, what would you tell them?

Devi : Sorry can you repeat?

[00:53] Audrey: Or if one of your friends for example build with bamboo, for example Ade? If she built in bamboo, what would you tell her?

Devi : They should build like the room for the relax.

[01:09] Audrey: How long do you think of bamboo construction can last?

Devi : 10 Years maybe,10 years maybe more.

[01:03] Audrey: Owner's home is already there 10 years.

Devi : And it looks new, a new home. I think it is like a new home.

[01:29] Audrey: Ok good.

Devi : But then, 10 years, I'm shocked! Because all, the furniture like small and all look fresh.

[01:41] Audrey: So do you think it can last more than 10 years?

Devi : Yes.

[01:46] Audrey: How long?

Devi : I think 15 years maybe.

[01:58] Audrey: Did you change your mind about bamboo construction during the visit?

Devi : No, same.

[02:11] Audrey: The visit didn't change the way you feel about bamboo?

Devi : No.

[02:22] Audrey: Can you think about something that would stop people from building with bamboo?

Devi : No.

[02:30] Audrey: What is the range of cost, from your point of view, is a bamboo House? Price?

Devi : I think it is expensive.

[02:39] Audrey: How much?

Devi : 15... No. I think until 20 million rupiahs.

[02:50] Audrey: For a home how big?

Devi : For a home like Owner's.

[02:57] Audrey: Ok so 20 million.

Devi : Yes.

[03:00] Audrey: To sum up is there's something you want to add or to tell me? Is there a question you want to ask me?

Devi : I think no.

[03:13] Audrey: Ok, well thank you then. It's finished. Thank you very much. Suksuma!

R. TRANSCRIPT 15 – IN-DEPTH INTERVIEW OF NGURAH WIDI, RETIRED

Ngurah : Ok so can I read the questions first?

[00:03] Audrey: Yes, of course.

Ngurah : Because for the English... Uuh. Description...

[00:21] Audrey: This is in French, it describes how this is supposed to go. I describe the questions and then the visit.

Ngurah : Now here, from now, I'm going to ask you to repeat your name, where you live, your age and your job.

[00:30] Audrey: And then the other questions. So this is the beginning of the question.

Ngurah : What are the pros and cons... What is pros and cons?

[01:10] Audrey: It is the good and bad, you know?

Ngurah : Of this material?

[01:16] Audrey: Yes the advantages and disadvantages.

Ngurah : Pros is advantages?

[01:24] Audrey: Yes and cons is disadvantages.

[Ngurah continues to read the questions]

Ngurah : What a barrier?

[02:34] Audrey: Something that stops you.

Ngurah : And encouraging?

[02:58] Audrey: It's something that will push you to use it, to encourage. I am going to translate that word for you in bahasa indonesia. Wait...

Ngurah : I have to answer this in English or Indonesian?

[03:18] Audrey: If you can answer in English, English is better but if you really don't know you can say it in Bahasa Indonesia, helping me to translate. Her, encouraging in Indonesian is this: [shows it on the screen].

Ngurah : What is to sum up?

[04:17] Audrey: To finish, or to resume.

Ngurah : [continues reading]

[04:47] Audrey: And then after that, it is finished, we will go to the visit.

Ngurah : Now?

[04:55] Audrey: No after this.

Ngurah : Ok. Can I have one copy?

[05:06] Audrey: Actually this my copy, I've only one.

Ngurah : Oh just one copy.

[05:10] Audrey: Yes. So can I ask you to repeat your name?

Ngurah : Kristi Ketut Ngurah Widi Arthur.

[05:18] Audrey: And where do you live?

Ngurah : I live in Blumbungan.

[05:24] Audrey: Ok, and how old are you?

Ngurah : Now I'm 65 years old.

[05:30] Audrey: And what is your job or main occupation?

Ngurah : I am retired from educational for the department.

[05:48] Audrey: Now could you tell me about your home? How many people live here with you?

Ngurah : So I live with my wife and my granddaughter.

[06:08] Audrey: What are the convenience you have? So you have a kitchen... Many rooms in your house?

Ngurah : So I have a kitchen, I have a dining room, I have a bedroom and toilets. And also I have a place to sell somethings.

[06:32] Audrey: Ok, and what are the materials that are used to build your home?

Ngurah : I use brick and cement and wood.

[06:45] Audrey: What would you say are the most used materials in Bali?

Ngurah : In the city most of the material used Brick and Wood. But in the countryside most people use bamboo and also materials around they live.

[07:20] Audrey: Ok so we're done with the first part, as we were really quick we might want to skip the break. If that is ok?

Ngurah : Uh uh.

[07:34] Audrey: I'd like you to tell me about the pros and cons of the material that you that you use in your house? What are the good things about brick and cement and wood?

Ngurah : So actually the bamboo buildings most health than brick and wood. But the bamboo construction is less strong than brick and wood.

[08:08] Audrey: Strong against what?

Ngurah : Lasts... Maybe the bamboo 20 years of 15 years until 20 years. But the bricks until 30 years and more than that.

[08:23] Audrey: And why is Bamboo going to end after 20 years, what is going to happen?

Ngurah : In Balinese we don't use chemistry and things like that, it isn't natural. I don't know they just get things like this.

[08:48] Audrey: Oh dust?

Ngurah : Yes. For example with the insects inside. And then there is this.

[08:58] Audrey: Ok, so this falls. If in your house you wanted to build a new construction, what would you like it to be?

Ngurah : I'd like to use brick and wood. Because it is easy to take care of. In Indonesia, I don't know what it is called, bamboo is... Uh... I will speak Indonesia. [speaks Indonesian: I like to use bricks and woods. Because these is easy to take care. Bamboo is preferred by "Ani-ani" (honey bee) in Bali. And they have insect or termite inside the bamboo.] And then other insects.

[09:50] Audrey: Will eat it?

Ngurah : Yes, they will eat it.

[10:00] Audrey: Ok. So what are the first things that come to your mind if I ask you about bamboo construction?

Ngurah : The bamboo construction is... uh... what is it? Good and arts and natural.

[10:22] Audrey: Now if one of your neighbours or one of your friends here build a house in bamboo, what would you tell them?

Ngurah : For me it is very natural which is good for me.

[10:37] Audrey: How long do you think a bamboo house lasts?

Ngurah : Until 15, until 20. 15 years until 20 years.

[10:50] Audrey: Can you think of anything stopping people from using bamboo?

Ngurah : Stopping? Because to build with the bamboo material it is very expensive take care of, we have to often take care of that.

[11:07] Audrey: Ok so the maintenance?

Ngurah : Yes, the maintenance. It is more maintenance used bricks and things like that.

[11:14] Audrey: Is there relation to stop people from building with bamboo? Does the government do anything to stop people from building with bamboo? Can you choose any material?

Ngurah : No, no, no. The government allows everyone to use bamboo construction the government also advises the villagers to use the materials from nature in Bali.

[11:46] Audrey: Ok good. I'm going to ask you to rank this three materials. So this is Bamboo, brick and concrete, beton. Where does brick comes from earth that you take, you cook it. This is concrete, from sand, cement, rocks and water. Now I want you to rank it from the cheapest to the most expensive.

Ngurah : This is cheapest, this is the cheapest one. And then this and then this.

[12:28] Audrey: So I repeat for the record: bamboo is the cheapest, and then concrete is medium, and brick is the most expensive. I am going to show you pictures and I am going to ask you to choose three you can choose them because you like them or you can choose them because you don't like them.

Ngurah : So I have to choose three of this? So the first I like this, and then this. And then this one.

[13:51] Audrey: Now can you take these pictures and tell me why you chose them?

Ngurah : Why I chose them so these three pictures, they are really close with nature. Like this. It is good for the bamboo with this, with the nature and with the forest.

[14:28] Audrey: What do you like in this construction? Do you like the colours or the shapes maybe?

Ngurah : I think the colours is good, still natural you know. It is much with this in this.

[14:48] Audrey: With the green and the beige?

Ngurah : Yes.

[14:55] Audrey: How about the shape of the house?

Ngurah : The shape?

[14:59] Audrey: Do you know what shape is?

Ngurah : In Indonesia: aman? [Indonesian for safe]

[15:08] Audrey: No bentuk.

Ngurah : Oh bentuk, can you repeat your question?

[15:12] Audrey: What do you think of the shape?

Ngurah : Yes the same for me is very very artistic.

[15:18] Audrey: Do you think artistic is good or not good?

Ngurah : Good for me.

[15:28] Audrey: Ok very nice. Terima kasih. Can you think of strong incentives encouraging people to build in bamboo?

Ngurah : It depends on the material that they can find in the area.

[16:30] Audrey: Now to finish is there anything you want to say or add? That you haven't said already?

Ngurah : The bamboo construction, it is good for the health and then artistic.

[16:55] Audrey: Ok good, thank you.

S. TRANSCRIPT 16 – COMMENTED WALK OF NGURAH

[00:02] Audrey: So I am going to record you. Come this way. Now I want to know if you were to build a new construction, maybe storage, for your house, and this would be it, I'd like to know what you like or don't you like. So here we are. What do you think?

Ngurah : This building, what is it used for? Storage?

[00:47] Audrey: For storage. It could be used for something else. What would you use it for?

Ngurah : In my mind it is dirty. It's not clean and then the connexions with the hut, but when I see, it's dirty and not health.

[01:18] Audrey: Not healthy?

Ngurah : Yes. Not healthy.

[01:21] Audrey: And here do you think it is not healthy?

Ngurah : Yes because there is dust.

[01:30] Audrey: If we cleaned it, do you think the building is healthy?

Ngurah : Yes. Because you know the second one it is good for ventilation. You know with the... [shows the opening on the ceiling]. So the alang-alang, we call it in Indonesian alang-alang, for me the best look, alang-alang. Because when it is hot, it keeps cool. When it's cool, it keeps the hot. That is good, for me it is very very good this room. But they have to change it, every maybe about 10 years, you have to change it. When 5 years, it looks like not good, for me it is essential in order to be good-looking.

[02:49] Audrey: Do you like this place?

Ngurah : Yes I like this natural. What is it? Bamboo?

[02:56] Audrey: This one is mud. You take Earth, you compact it...

Ngurah : What is it inside? Just bamboo?

[03:04] Audrey: Yes, like this.

Ngurah : This is good to keep the weather good. To keep cool, what is it?

[03:24] Audrey: Ventilation?

Ngurah : No...

[03:26] Audrey: Air-conditioning?

Ngurah : Yes, you don't need! Because when I was a child my grandfa we used this. Mud.

[03:39] Audrey: So in your house, when you were little, you had mud?

Ngurah : Yes, but I didn't know this was mud because when I was a child it was big.

[03:49] Audrey: Big wall, thick?

Ngurah : Yes. That's good I didn't think that was mud.

[03:57] Audrey: Do you like the touch, the textures, do you like this?

Ngurah : Yes it's natural. But if you build in the city, this is you know, very different from other system. But if you build it in this situation it is really good.

[04:13] Audrey: Why is it not good for the city?

Ngurah : Because it's not around you. If you have a city where most people dislike this it is good. If you on the other side and the other side build different, more than building, it is not good.

[04:35] Audrey: Why is it not good?

Ngurah : I think, you know, because like this, for me, it looks clean. But if you build like this, in this situation, this is very good.

[04:57] Audrey: Ok now we are going to go to the other place. This is the camera. Follow me. Careful, don't fall.

Ngurah : This is alang-alang.

[05:32] Audrey: Yes, this is alang-alang but it's old.

Ngurah : Yes maybe 5 years, so we have to take care of it.

[05:58] Audrey: Go ahead, don't forget to take off the shoes before we go in. This is a home. This is a house. Here, come in. Be careful with the cables. Now here, I will let you walk around you can go to the kitchen, the bedroom or upstairs.

[Ngurah goes to the owner, who he knows]

Ngurah : This is your place?

Owner: This is my home!

Ngurah : You have a nice home!

[00:03] Audrey: Do you think it is nice?

Ngurah : Yes, yes, very very artistic and natural. And you don't use air condition?

Owner: No.

Ngurah : That's very natural, that is very healthy! I cannot build like this, very expensive.

[00:03] Audrey: So do you think this is more expensive than concrete?

Ngurah : Yes. If you build like this it is more expensive than concrete.

[00:03] Audrey: So when you were thinking it before it you put bamboo as very cheap. But no you're telling me this is very expensive.

Ngurah : It depends when you showed me the buildings, it depends. Like this, I think so, is very expensive, not the material. Takes care of this building. To maintain. It makes it more expensive than... When you start to build I think cheaper than this, but when it is very long, more expensive this. I don't know, Owner, do you take care of this?

Owner: The roof is expensive.

Ngurah: With the alang-alang and having to change it. Alang-alang is more expensive than regular.

Owner: But I mean, how often do you refinish a concrete house?

[speaks in Indonesian:

Owner: How often you finish the concrete house? How many times you repaint?

Ngurah: I build this house since 2008 until now 2019. It's been 11 years. And still good. It depends, if the first work is not good, this only survive 2 years. How about ants? Is there any ants?

Owner: Yes, there is. For the first step we made the floor without any planning, so the result is not good for the bamboo house. On the other hand, if the first step we make the floor with good planning and our aim to get a good house with bamboo, it is be good then. And also good for house from concrete and with roof-tile or iron sheeting, it's all the same as long as we make planning before.]

[00:03] Audrey: I definitely have to translate this. I think it's interesting, I was missing on a lot.

[enters a friend of the owner who knows Ngurah as well, we all chat]

[12:27] Audrey: Do you have anything to say or do you want to add something? You maybe want to go upstairs to see the roof?

Ngurah : Ok.

[12:35] Audrey: Be careful in the stairs. What do you think of the stairs?

Ngurah : I have to be careful it's a bit slippery.

[12:50] Audrey: Yes. So slippery? Ok.

Ngurah : There's sounds.

[12:55] Audrey: It makes noise.

Ngurah : What is it?

[13:05] Audrey: There's a cat. So what do you think of here? What do you like what don't you like?

Ngurah : I like the construction style. It's a style that I like. But maybe when I was a child, so my parents and my grandpa used everything used bamboo, and then like this roof and all. Because they used to stay in bamboo buildings, I think I just want to make the new one. But when I see that I remember was a child, for me this is back to when I was a child, and that is good.

[14:08] Audrey: Ok, so good memories!

Ngurah : Yes I like it. But now when won't it end sometime... What they call [Indonesian word]. But the building like this you know needs, what is it: take care?

[14:37] Audrey: Maintenance?

Ngurah : Yes maintenance. It's very need time to maintenance. To clean and things like this.

[14:50] Audrey: Do you think it takes more time than a brick or a concrete construction?

Ngurah : It is more long to build it than brick construction. But it also depends on the site construction. Construction like this is more longer than when we builds... I think when I build with my experience like this building maybe you just need one month to build like this with the brick. But I think when I build like this, it is more... If you make it like this you build one by one. If you buy the ready one, it's very quick but more expensive. If you start from the raw material, it makes very long time. So when I was child, my grandfa he made himself one by one.

[16:10] Audrey: Very long!

Ngurah : Very very long.

[16:13] Audrey: How long?

Ngurah : Maybe one like this just takes 2 hours, this one. It's long about 4 meters.

[16:37] Audrey: And for the whole roof do you remember how long?

Ngurah : It depends sometimes they were 10 people to make it but when one person to make it maybe it takes around, it depends on the experience of the man. If she is experienced, maybe 30 minutes or 1 hour to make one.

[17:00] Audrey: You know a lot of things, you already know a lot of things about bamboo.

Ngurah : If there is no chemicals.

[17:09] Audrey: There's going to be little holes and then there's going to be dust. But here it's been 10 years, and there's no holes and it's still smooth.

Ngurah : I like the natural, good for ventilation and change of the air.

[17:30] Audrey: Air circulation?

Ngurah : Yes, air circulation.

[17:36] Audrey: Ok well very good. Be careful on the way down, don't fall.

Ngurah : If you make yourself, but if you buy already done it is very quick.

[18:10] Audrey: Is it cheap if you buy it already done?

Ngurah : Yes because now there's a lot of people making it, in Bangli or... Back then there was none, so it was my grandfather who made it. But now everyone you find...

[18:24] Audrey: Do you want to check out the bedroom? So this is the bedroom and the bathroom. Would you have a bedroom like this for you? Would you have a bedroom like this for you? Do you like this bedroom?

Ngurah : HUUU... There are many holes you know [airtight]. I don't like this many many holes.

[19:04] Audrey: For the mosquitoes?

Ngurah : Yes. [laughs] short time yes maybe one week maybe one month, for long-term I need like this. If you rent it just one month or just two months, that's for a long time for me it is not good. This is the bathroom?

[19:37] Audrey: This is the bathroom.

Ngurah : Interesting.

[19:56] Audrey: Ok do you have anything more you want to say?

Ngurah : That's all?

[20:06] Audrey: Yes that's all.

Ngurah : Owner thank you, bye-bye. [speaks Indonesian]

T. TRANSCRIPT 17 – INTERVIEW POST COMMENTED WALK OF NGURAH IN THE WAKE

[20:57] Audrey: I still have a couple of questions and then I'll let you go back. So did you like the house?

Ngurah : Yes.

[21:27] Audrey: Did you know Owner already? Did you know Owner from before?

Ngurah : Maybe he knows me but when we have a gathering, we join the Kulkul farm group when I was retired. But after retired we open the market and we have to school. A professional school. So we open, here we call it, my school Widia Mandala. This is a professional school so we have a program mechanic automatic, and then cook and hotel accommodation.

[22:25] Audrey: Nice, very good.

Ngurah : And then the school has a program in Denpasar: nurse.

[22:43] Audrey: You can sit here and I will ask you a couple more questions.

Ngurah : Ok.

[22:51] Audrey: So how did you feel in the visit?

Ngurah : I feel, what is it? Just I remember when I was a child because I used to live in like this house. So when... it was in about 1965.

[23:16] Audrey: For how long? How many years?

Ngurah : I leave my village at 1970 to go to Denpasar for the school, to continue my school. When I was secondary, elementary school and secondary school, I was there in a bamboo house.

[23:42] Audrey: What was the village?

Ngurah : Ubud. Ubud in 1965 it was like like this. A lot of bamboo. My house is covered with bamboo. When my father build a house, just cut the bamboo and then no chemistry. Not not not.

[23:59] Audrey: No treatment?

Ngurah : What is it?

[24:05] Audrey: The treatment, the freemite, the borax...

Ngurah : Not treatment. So when he cut the bamboo, he chose the good day for this. Just the good day.

[24:19] Audrey: Like a calendar?

Ngurah : A calendar. So yes. And the old one, not the young one, the old ones.

[24:27] Audrey: How long did the house last?

Ngurah : Like this, like 20 years, 25...

[24:42] Audrey: Would you build in bamboo now? Would you choose bamboo for a new house?

Ngurah : Yes, if I have... I'd like to build with bamboo if I stay in like this situation, I don't build with brick, I build with the bamboo. When I stay in like this. Because the brick construction, the cement construction is not good in this situation.

[25:21] Audrey: Ok, but you live close to here, you live in the village, you don't live in a big city. You don't build in bamboo though.

Ngurah : Yes, when I live in the city, I don't use bamboo. If I live like this, maybe I choose bamboo.

[25:48] Audrey: And how long do you think that house will last?

Ngurah : Maybe about 20, 20 years.

[25:58] Audrey: Did you change your mind on bamboo construction when we visited the house? With the visit today, did you change your mind on bamboo?

Ngurah : Change my mind? I just like to build with bamboo, it depends on the situation. Change minds, so what I said, I like to stay in like this stay if I live in this situation.

[26:52] Audrey: What do you mean by this situation.

Ngurah : In this kind of area, many trees. But in the city, there is not like this.

[27:00] Audrey: Where you live, do you call that the city?

Ngurah : In Denpasar.

[27:05] Audrey: I mean in Blumbungan. There is nature, right?

Ngurah : In Blumbungan, this is for the guest house, you know?

[27:26] Audrey: Ok. You don't live in Blumbungan?

Ngurah : I stay there sometimes but sometimes I live in Denpasar. Sometimes I live here.

[27:36] Audrey: Ok, I didn't know that.

Ngurah : That's why in here we use the door like Balinese you know. No many take care, we just clean. If we used this, it's very hard to clean. Cheap for the take care of this.

[28:14] Audrey: How much do you think a house like that costs?

Ngurah : Maybe 150 million to build like this.

[28:27] Audrey: And to sum up, do you want to remind me the pros, the advantages of bamboo and cons?

Ngurah : The advantage is it is natural and then it is good for the air, air circulation.

[28:53] Audrey: Natural ventilation?

Ngurah : And then what is it? It it more health when we always stay with the bamboo than stay with the brick you know? I think, what is this... [touches his nose]

[29:12] Audrey: The smell or...?

Ngurah : Maybe in brick, but the bamboo is natural. It affects my lungs. These are the advantages of the bamboo. The un-advantage, the worst of the bamboo take care should be half time to take care of this. And the second it that if there is no chemicals, worse... What is it?

[29:58] Audrey: Treatment?

Ngurah : Yes, then many ants come in.

[30:06] Audrey: Insects?

Ngurah : Yes. What is it the... lasts quickly. So we have to change. I don't know. In my house there is no chemicals, it's more difficult, just natural cut and then used like that. Not this one.

[30:45] Audrey: Yes this one is treated.

Ngurah : Is it the chemical effects now?

[30:52] Audrey: No, so you put it in a bath but then you let it dry. It's treated and dry so that insects doesn't want the dry material.

Ngurah : When I was a child, my parents just cut the bamboo and then put in the pool maybe one week until two weeks and then take out and let it dry.

[31:26] Audrey: Here, it is a bit like that but you add, in the pool, you add salts, special salt, boron salts, and the boron gets in the material. And then you dry it. It's dangerous when it's in the pool, you should wear glove to protect your skin, but normally, after it dries, it shouldn't get in your lungs. Very good. It's done. Terima kasih banya.

Ngurah : Terima kasih banyak.

T. IBCC CONTEST – HOUSE LOTI PROJECT

HOUSE LOTI

BAMBOO STRUCTURE FOR THE INTERNATIONAL BAMBOO CONSTRUCTION COMPETITION

BEIJING HORTICULTURAL EXPOSITION 2019

2019 04 29 1258 1063 69

Descriptive Report

1. PRESENTATION

1.1. PROJECT

Since the early landscape design, a balance between layout and water formed the basis of Feng'Shui. No landscape was complete without a pond, and no pond is complete without lotus.

Our goal: combine Western and Eastern construction, the traditional and the modern, to create a pavilion building that is adaptive, sustainable, and pleasant.

The word "blossom" inspired a dynamic design, being able to actually bloom: petals composing the walls of the closed flower can blossom into sunshade panels and seats.

The multifunctional pavilion has a small ramp to enter the first storey, about 50 cm above the ground. The second floor is only accessible using a bamboo ladder which can be hung upon a bamboo beam.

The structure is polyvalent and versatile as possible. The upper level can be used as a small resting space, for storage or even as a small office. The first floor might just be used for the same purposes, but it could also be used as for educational purposes. On top of the structure, a polycarbonate leaf shaped panel elevated from the top circular opening to provide the rain from getting into the pavilion whilst still letting light in and air out from the top. Thin interstices between the flooring slats will allow air to circulate from ground to sky, providing natural ventilation throughout the bungalow. (cf. Fig. 3)

The structure is covered with a two layers' skin made, from inside to outside, of bamboo woven panels and tent fabric. The fabric shall be 100% cotton, bio-epoxy covered and naturally dyed with yellow on top, left white

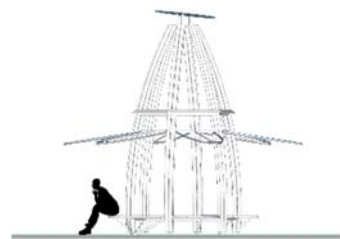

Figure 1- Man seating on a petal

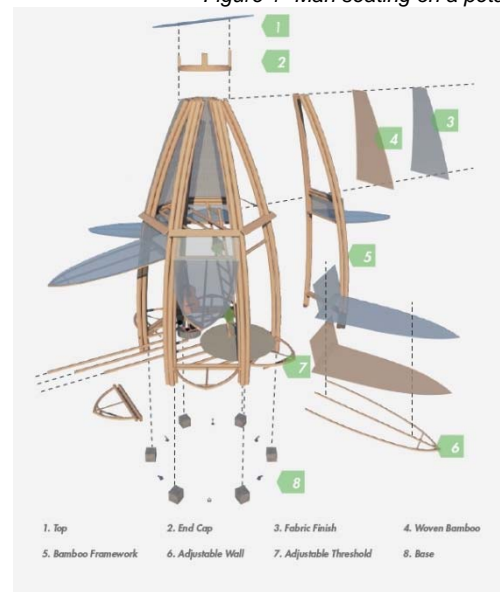

FIGURE 2- COMPONENTS OF THE STRUCTURE



(natural cotton white) for most of it and pinkish bits on the petal contours, using avocado for the pink and jackfruit and turmeric for yellow. These colours will recall some loti flowers.

FIGURE 3–BAMBOO FLOORING

1.2. STRUCTURE

The structure is made of six frames that are assembled with rope on site into a hexagonal shaped plan, primary floor structure and end cap on top. Each frame has 2 pivoting petals: 1 small pivoting into a seat and 1 large on top pivoting into a sunshade. The seat piece has a pivoting leg which can build into small metallic notch on the ground. The sunshades will be connected with a cable to a pulley system enabling the user to turn a hand crank opening the petals from the top floor or the ladder.

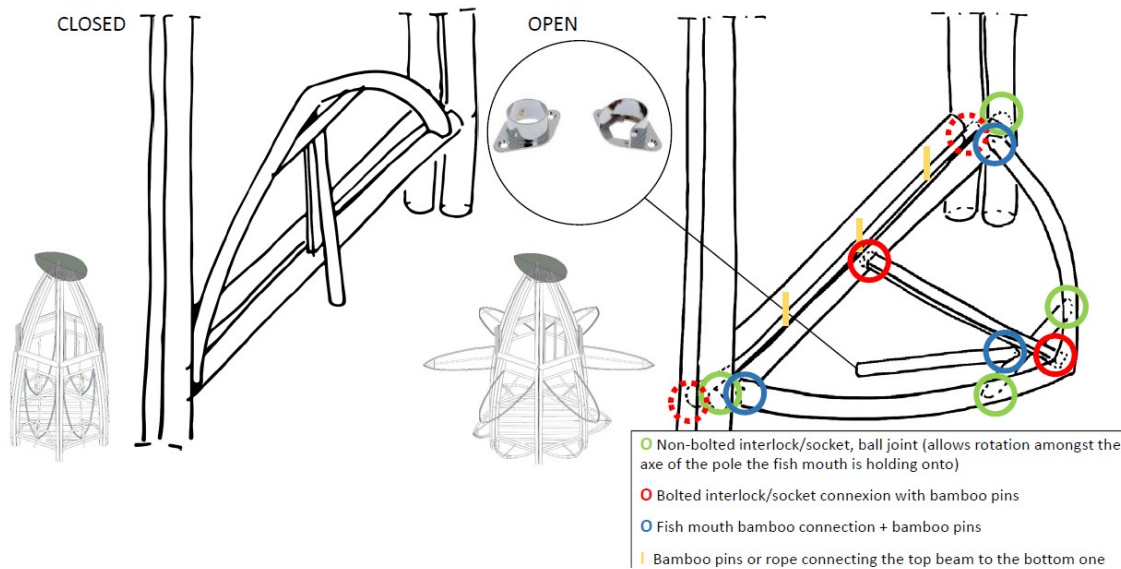

FIGURE 4– CLOSED AND OPENED SEAT PETAL AND TYPES OF CONNECTIONS

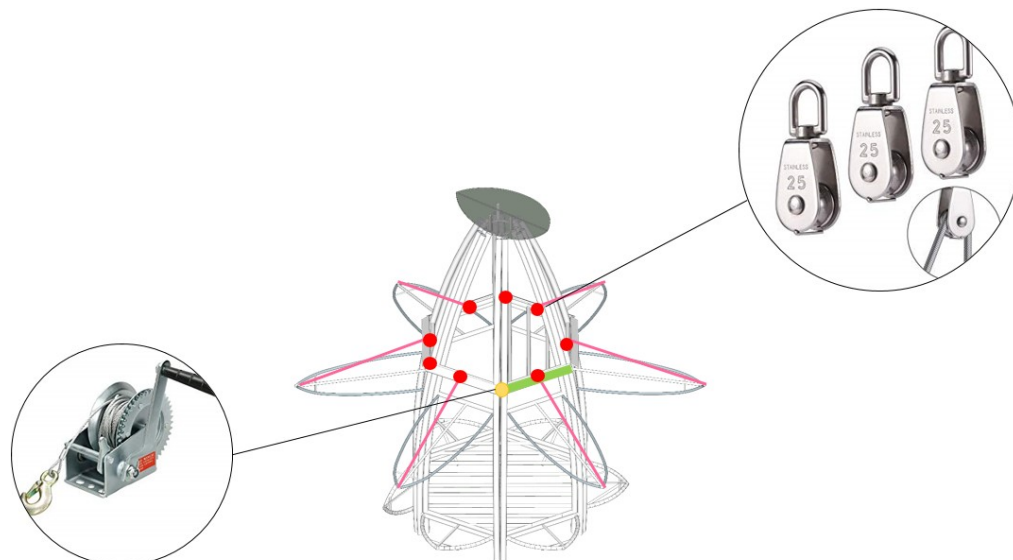

FIGURE 5– OPENED SUNSHADES AND POSITION OF THE CABLES (PINK) PULLEYS (RED) AND CRANK (YELLOW)

Small concrete foundation blocks are buried under the 6 major piles, connected with the structure by metallic connections (cf. *Fig.6*).



FIGURE 6– METAL PIECE FOR THE FOUNDATION CONNECTION

The sections used are described in the diagram below:

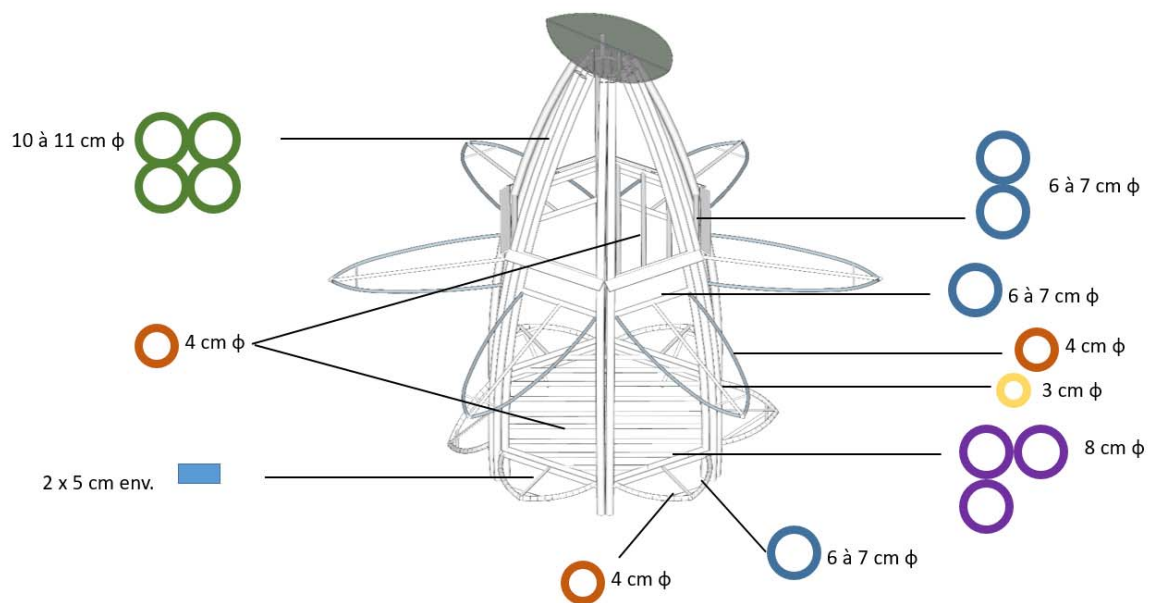

Figure 7– Bamboo sections

2. HYPOTHESIS

2.1. CONNECTIONS

Verifications of the connections is not detailed here but nevertheless respects the rules of good practices of the craftsmen of Belega, Bali.

2.2. MATERIALS

The main material used is Moso Bamboo. Its characteristics are the following:

- Density: 400kg/m³
- Elastic modulus: E = 9500 MPa
- Bending strength: $X_{m,d} = 20\text{MPa}$
- Compression strength: $X_{c,d} = 17\text{MPa}$
- Tensile strength: $X_{t,d} = 8\text{MPa}$

2.3. LOADS

- Self-weight: G
- Variable load: $Q = 4\text{kN/m}^2$
- Wind load: $W = 0.4\text{kN/m}^2$

The combination of loads in Serviceability Limit State is:

$$1.0 G + 1.0 Q + 1.0 W$$

The combination of loads in Ultimate Limit State is:

$$1.35 G + 1.5 Q + 1.5 W$$

2.4. NUMERICAL MODEL

The model was first made with Rhino 3D + Grasshopper then transferred to ROBOT Autodesk for the analysis.

3. RESULTS & VERIFICATIONS

3.1. SLS

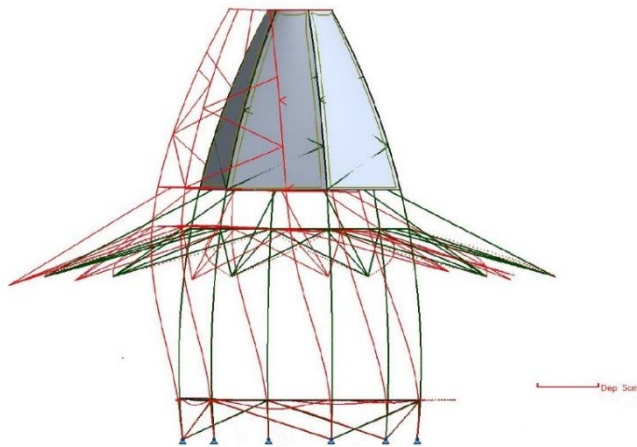

The maximal displacement at the top of the structure is equal to 5.9cm.

This displacement, corresponding to $H/93$, is acceptable.

Figure 8: Deformed structure in SLS

3.2. ULS

The table 1 shows the maximal results of the analysis conducted with ROBOT software.

Location of element	Section	Maximal compression force	Maximal tension force	Maximal bending moment
Horizontal Top	1 Φ 7cm	6.18kN	5.76kN	3.28kNm
Horizontal Bottom	2 Φ 8cm	6.80kN	4.39kN	4.25kNm
Vertical	4 Φ 10cm	14.15kN	9.55kN	3.22kNm

Table 1- Results of the analysis of the structure

The resistant forces and bending moment of each section is given in the table 2.

Section of element	Resistant compression force	Resistant tension force	Resistant bending moment
1Φ7cm	$= \frac{0.6 \pi^2 A E}{\gamma \lambda^2} = 12.58 \text{kN}$	$= A * X_{t,d} = 5.84 \text{kN}$	$= S_e * X_{m,d} = 3.39 \text{ kNm}$
2Φ8cm	$= 34.78 \text{kN}$	$= 15.28 \text{kN}$	$= 4.18 \text{ kNm}$
4Φ10cm	$= 14.37 \text{kN}$	$= 47.75 \text{kN}$	$= 5.63 \text{ kNm}$

Table 2- Maximal resistant forces and bending moment

Combined bending and axial tension/compression is also verified.

3.3. SUPPORT REACTIONS

The maximal support reaction is 7kN in tension. The steel connection to the foundation will be able to carry out this force.

4. CONCLUSION

The pavilion shall be safe and ready to be constructed.

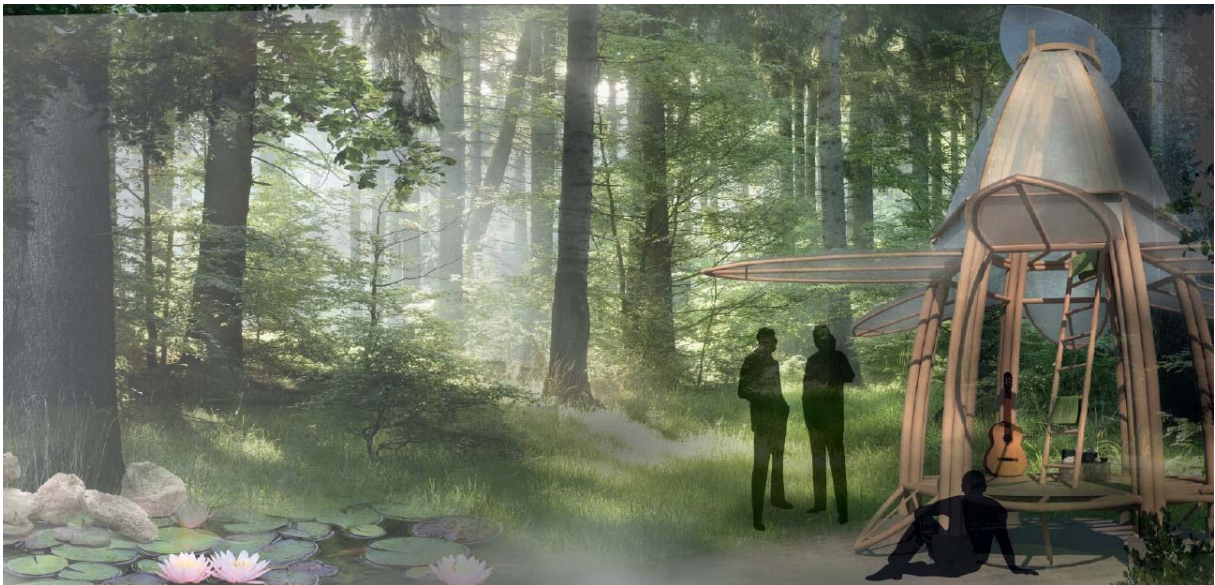

U. CONNEXION EXAMPLES

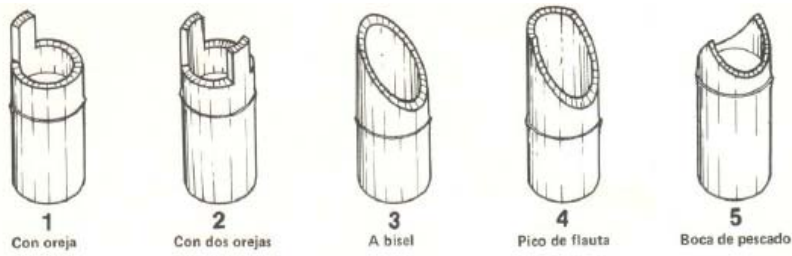

(Hidalgo & Diroux, 2018)

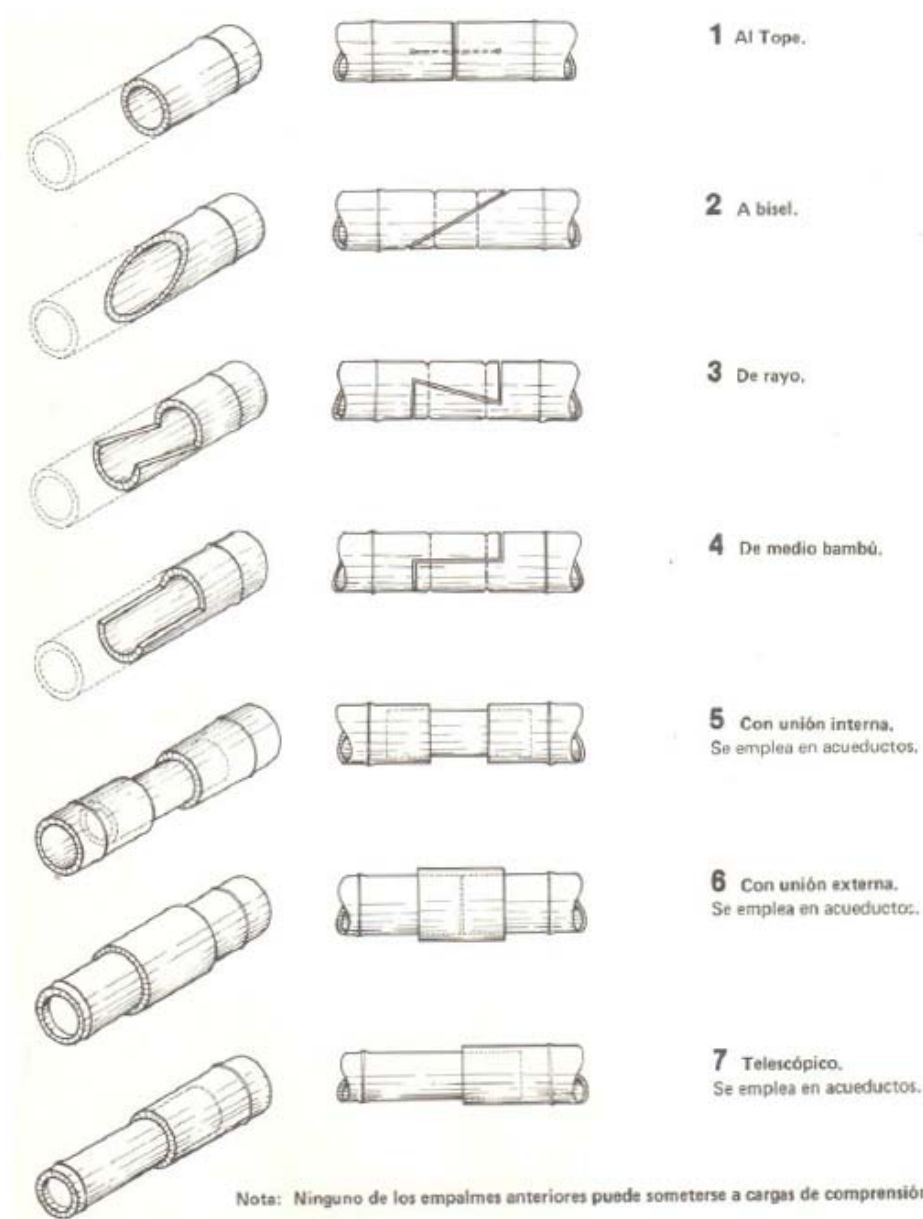

Nota: Ninguno de los empalmes anteriores puede someterse a cargas de compresión o de tracción.
 * MANUAL DE CONSTRUCCION CON BAMBU * OSCAR HIDALGO LOPEZ * CIBAM * UNIVERSIDAD NACIONAL DE COLOMBIA * FACULTAD DE ARTES *

(Hidalgo & Diroux, 2018)

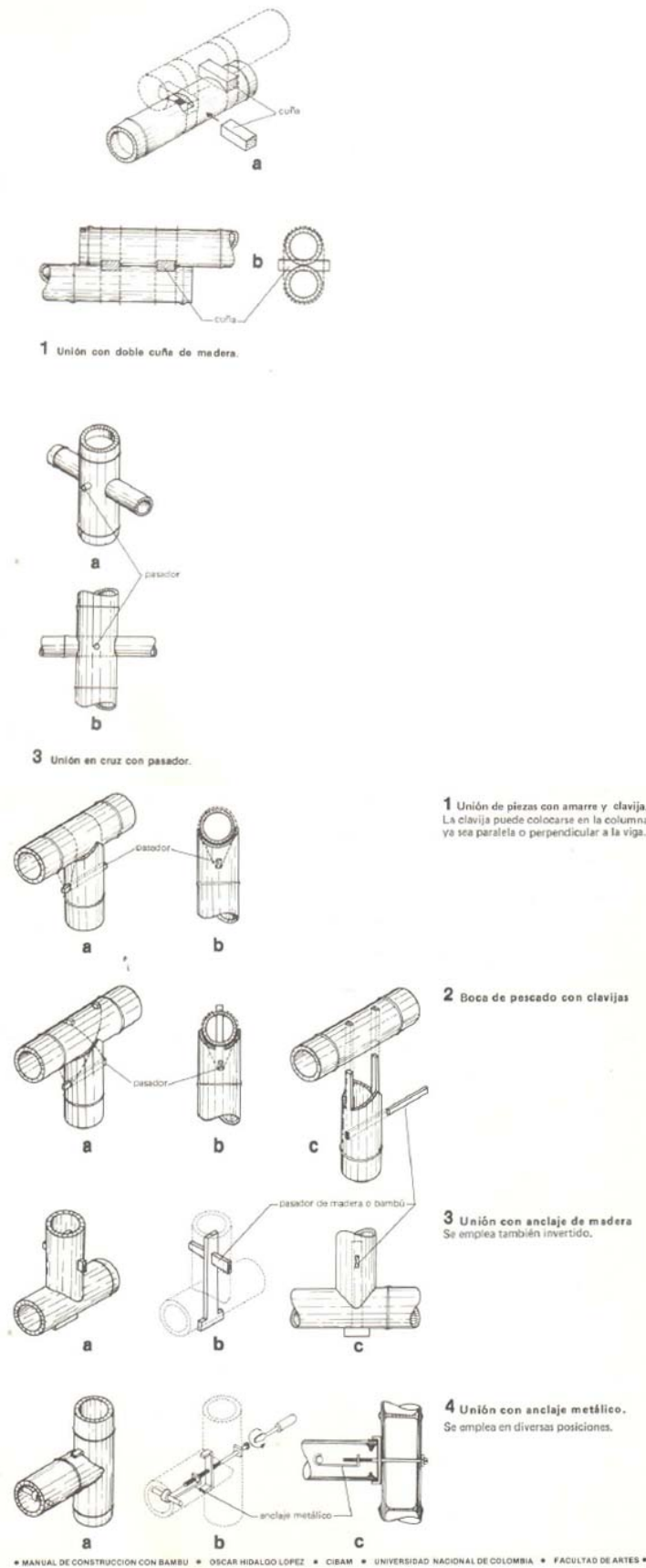

(Hidalgo & Diroux, 2018)

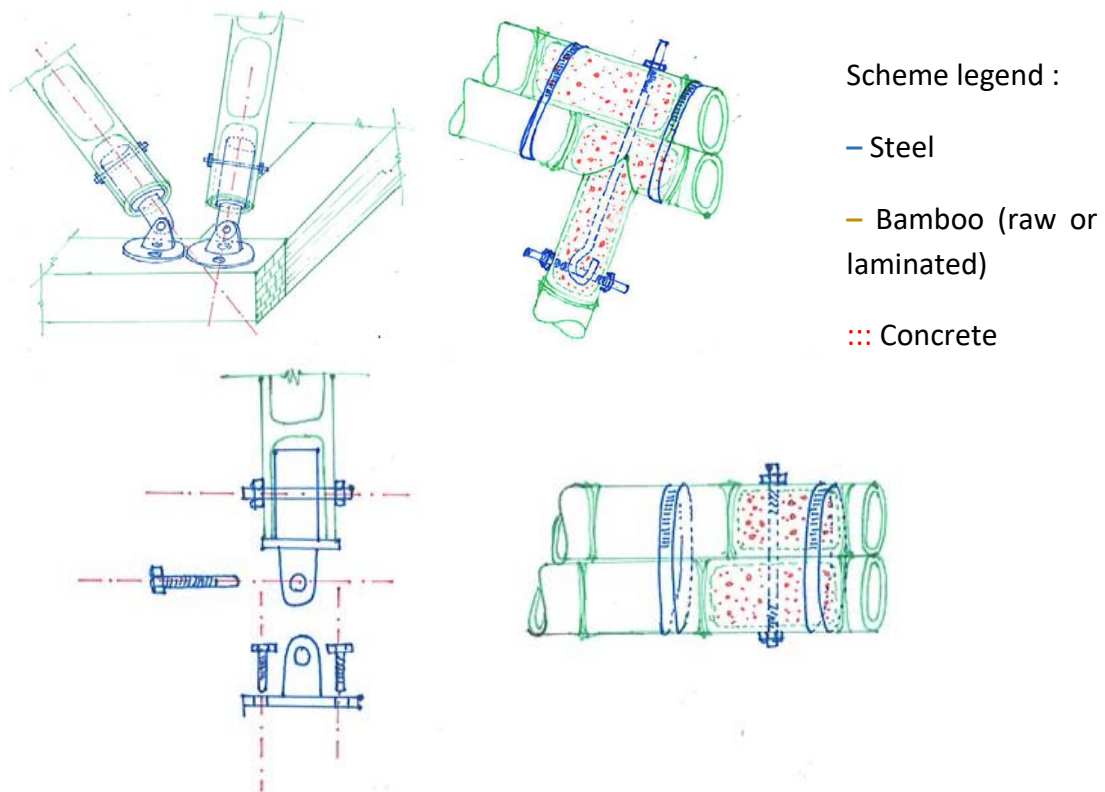

(Gonzalez, Frazer Mills, Buchhorn, 2019)

V. FURTHER DATA COLLECTED

V.1. ADDITIONAL DIAGRAMS

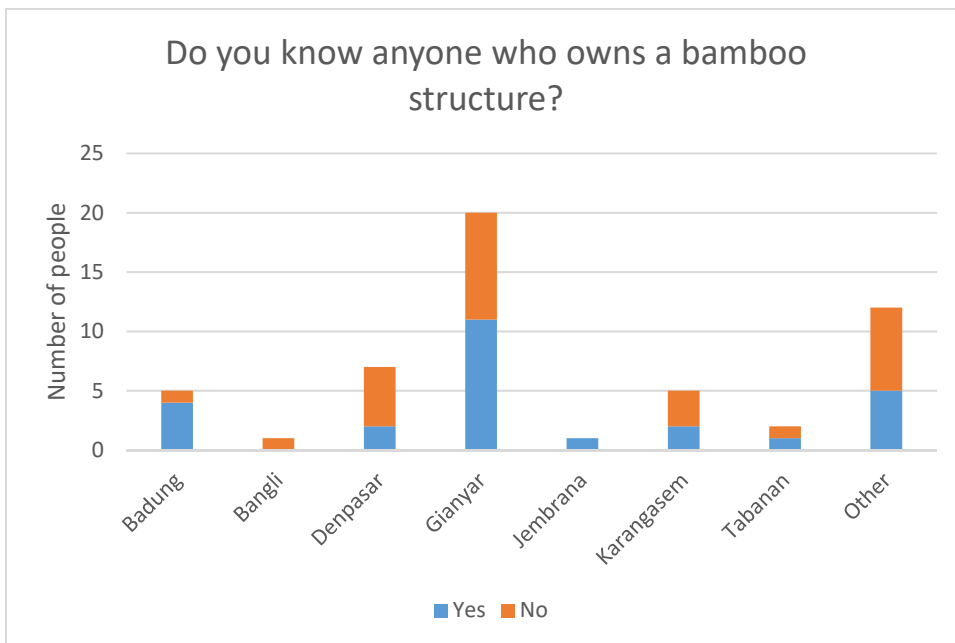
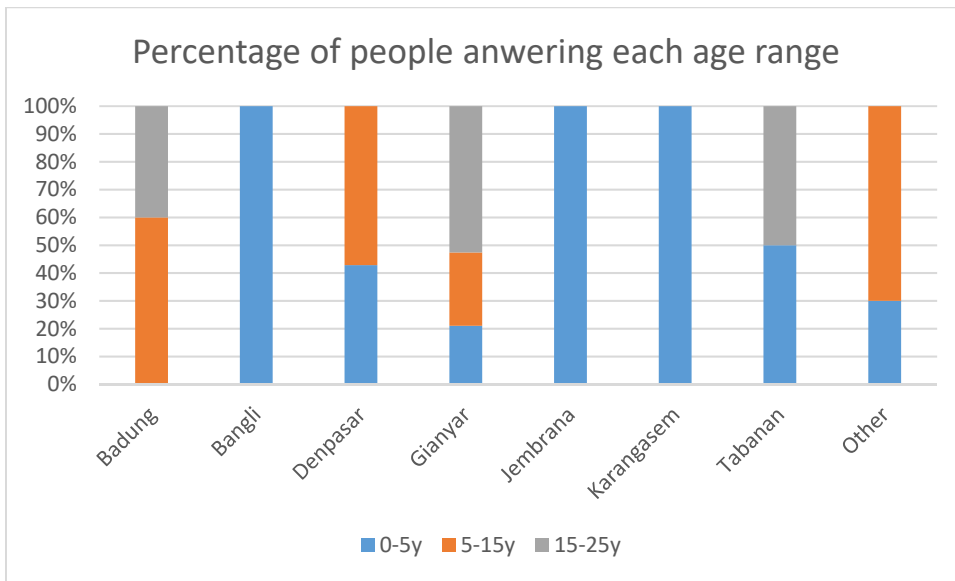

V.2. PICTURES OF THE COMMENTED-WALK BUILDINGS

First building visited, the storage extension:



(1)



(2) (3)

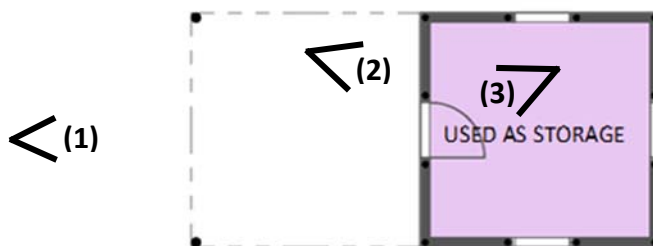

POINTS OF VIEW

Second building visited, the owner's home:



(1)



(2)



(3)



(4) Mezzanine

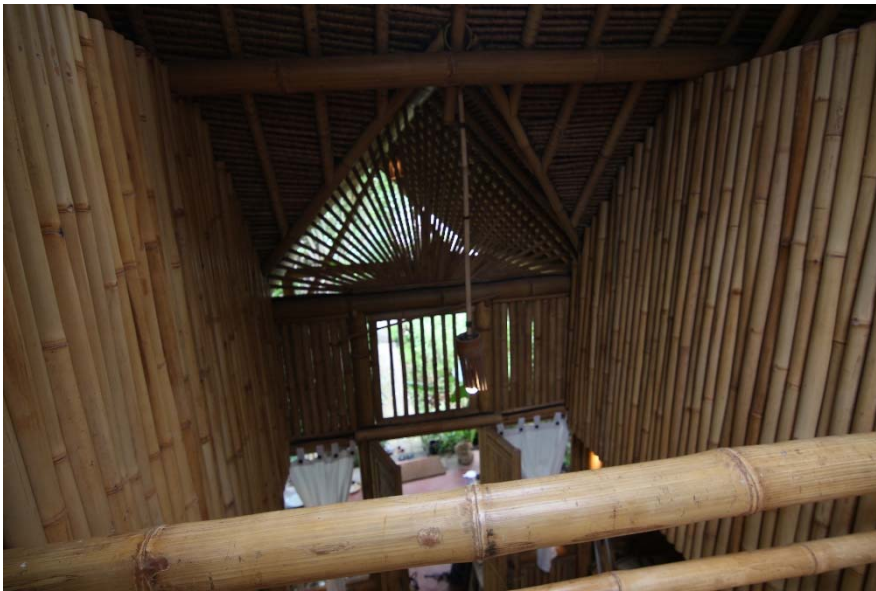

(5) Mezzanine

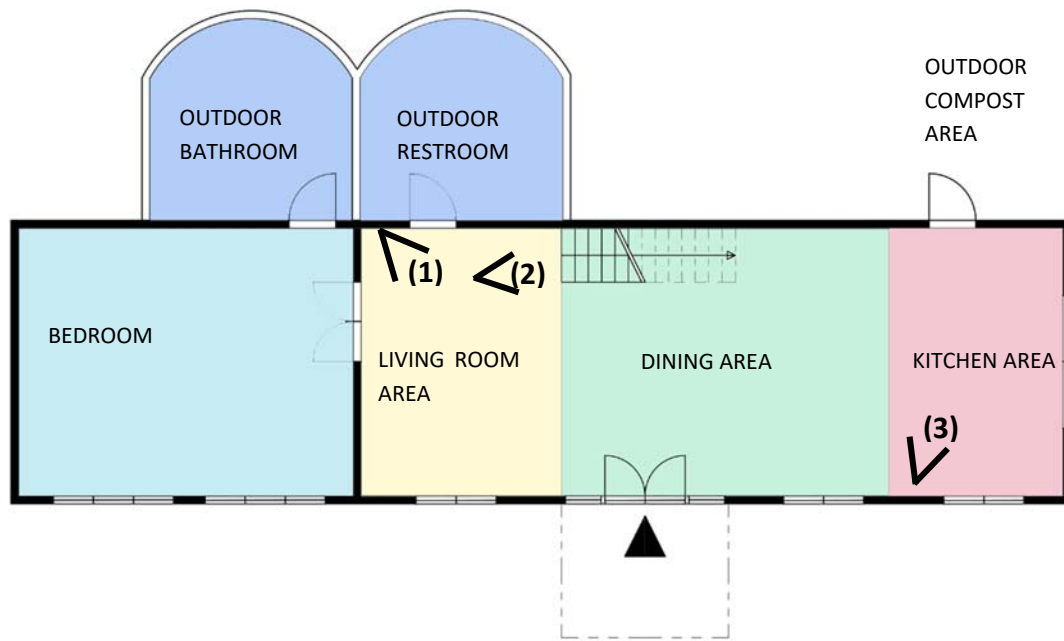

GROUND FLOOR POINTS OF VIEW

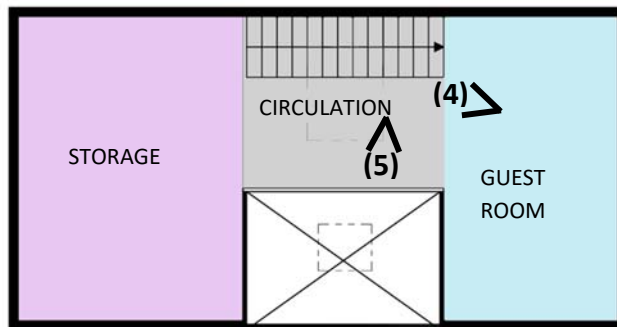

MEZZANINE POINTS OF VIEW

BAMBOO CONSTRUCTION

QUALITATIVE INDICATORS FOR HOUSING

Case study in Bali, Indonesia

Université de Liège – Faculté des Sciences

Appliquées

Master Thesis in order to obtain a master degree in
Civil Engineering and Architecture

by **Audrey MERTENS**

Academic year : 2018 – 2019

Promotor : C. ELSEN

Co-promotor : J.-M. FRANSSSEN

Jury members : S. REITER

J.-M. BLEUS

F. COURTEJOIE